

Service Bulletin.

STEERING GEAR

PV 444-445

Modification in steering gear, part no. 250051

The above-mentioned steering gear is now being delivered with a light-alloy cover with a cast-in bushing. In this connection, certain of the adjusting components are altered. These alterations are shown as follows:

Early production

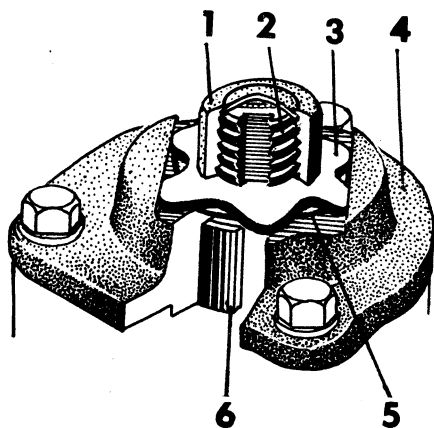

Late production

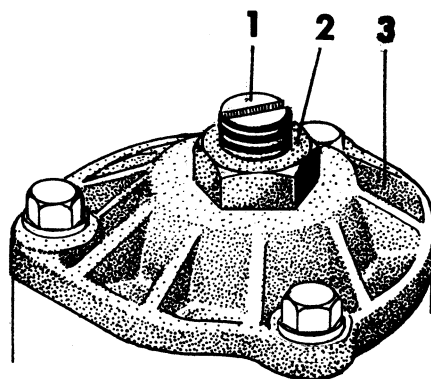

1. Cap nut	part no.	85621
2. Adjuster screw	" "	85620
3. Lock washer	" "	85622, 85629
4. Cover (cast-iron)	" "	85603
5. Gasket	" "	15522
6. Bushing	" "	85604

1. Adjuster screw	part no.	656713
2. Lock nut	" "	190766
3. Cover (light alloy)	" "	85630

The bushing which is cast into the light-alloy cover is fully finished. The special tool SVO 2226 is therefore only used after replacement of the bushing in the steering gear with part no. 250051 with a cast-iron cover.