

Service Bulletin.

Only for Volvo Dealers Service Bulletin file.

Re: Fitting of universal joints

On the front and rear universal joints there is a strip holding together two of the needle bearings. When fitting this strip, it is important to ensure that it is correctly positioned in the recesses in the flange (see illustration below). Otherwise the bearing will be distorted to an oval shape when the U-clamps are tightened.

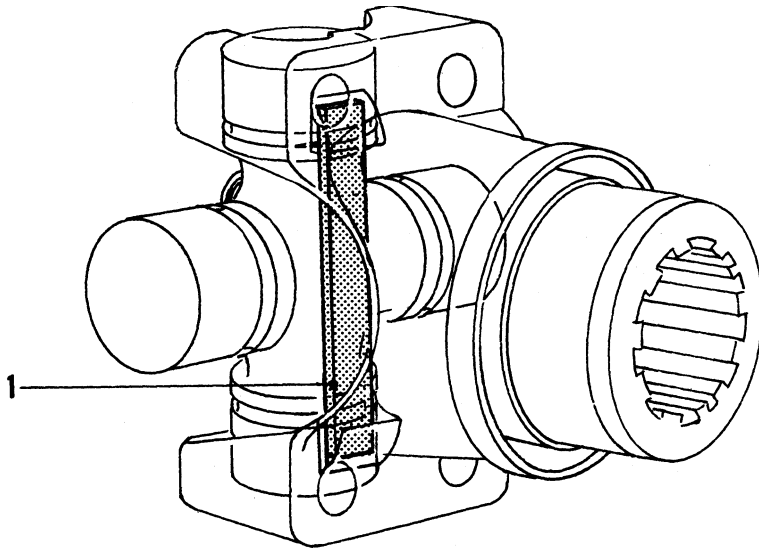

In order to avoid damage to the needle bearings, we request you to check universal joint assembly during the delivery inspection or when servicing the cars.