

# STEERING COLUMN SWITCHES

1995 Volvo 850

1995-96 ACCESSORIES & EQUIPMENT  
Volvo Steering Column Switches

850

## TESTING

NOTE: Testing information on steering column switches is not available from manufacturer.

## REMOVAL & INSTALLATION

WARNING: Before any repairs, disconnect and shield negative battery cable from ground. Disconnect Yellow and Orange Supplemental Restraint System (SRS) connectors on driver's side of center console, near accelerator pedal, to avoid accidental air bag deployment. Follow air bag service precautions. See SERVICE PRECAUTIONS and DISABLING & ACTIVATING AIR BAG SYSTEM in appropriate articles;  
For 1995 850, see AIR BAG RESTRAINT SYSTEM,  
for 1996 850, see AIR BAG RESTRAINT SYSTEM articles.

## STEERING WHEEL & HORN

### Removal

1) Ensure front wheels are pointing straight ahead. Mark steering wheel-to-column location for reassembly reference. Remove air bag module. See Fig. 1. See AIR BAG MODULE under REMOVAL & INSTALLATION in appropriate articles;

For 1995 850, see AIR BAG RESTRAINT SYSTEM,  
for 1996 850, see AIR BAG RESTRAINT SYSTEM articles.

2) Remove steering wheel hub retaining bolt. Remove plastic warning label retaining screw from steering wheel, leaving screw attached to plastic warning label. Insert screw into hole, locking contact reel pin. Carefully pull steering wheel from column, allowing wiring and plastic warning label to pass through hole in steering wheel. See Fig. 2.

### Installation

To install, reverse removal procedure. To properly adjust contact reel and complete installation, see CONTACT REEL CENTERING under ADJUSTMENTS in appropriate articles;

For 1995 850, see AIR BAG RESTRAINT SYSTEM,  
for 1996 850, see AIR BAG RESTRAINT SYSTEM articles.

Tighten steering wheel retaining bolt to specification. See TORQUE SPECIFICATIONS.

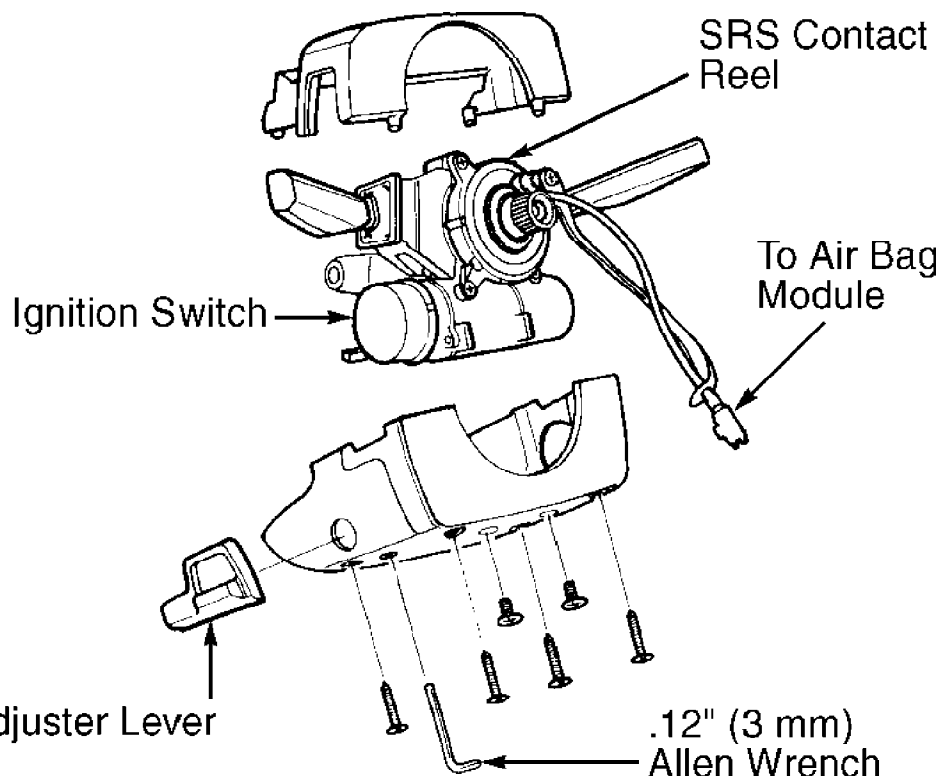
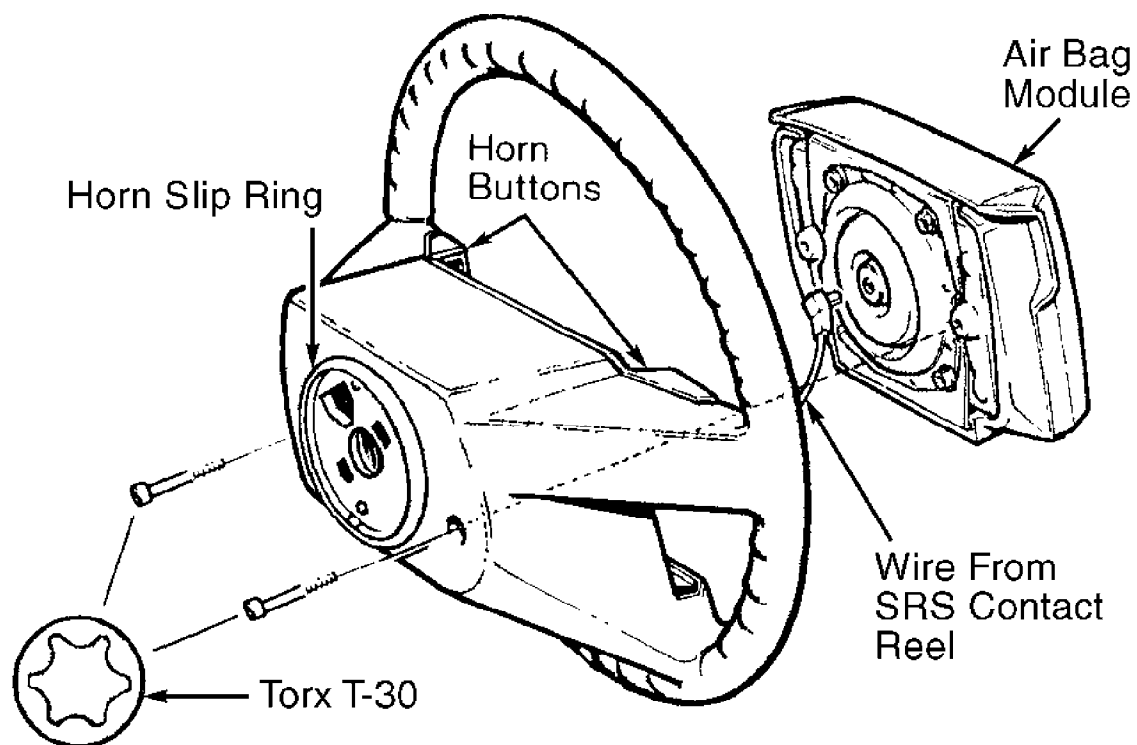

91A01556

Fig. 1: Removing Air Bag Module  
 Courtesy of Volvo Cars of North America

Steering Wheel  
Center Bolt

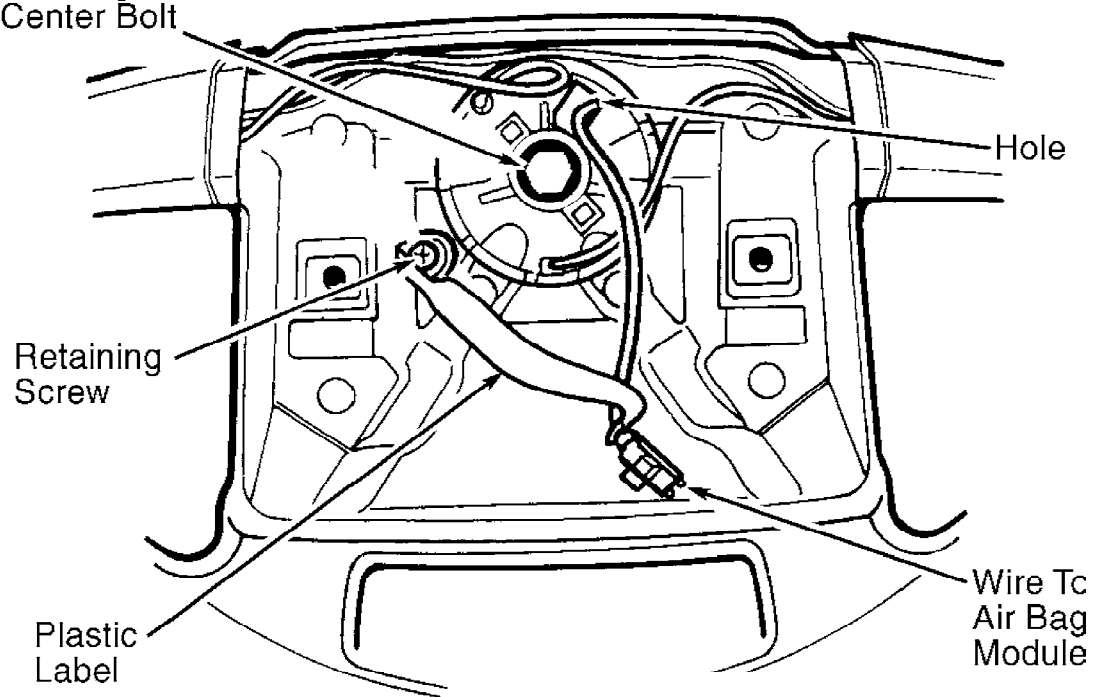

Retaining Screw Locking  
Contact Reel Pin To  
Remove Steering Wheel

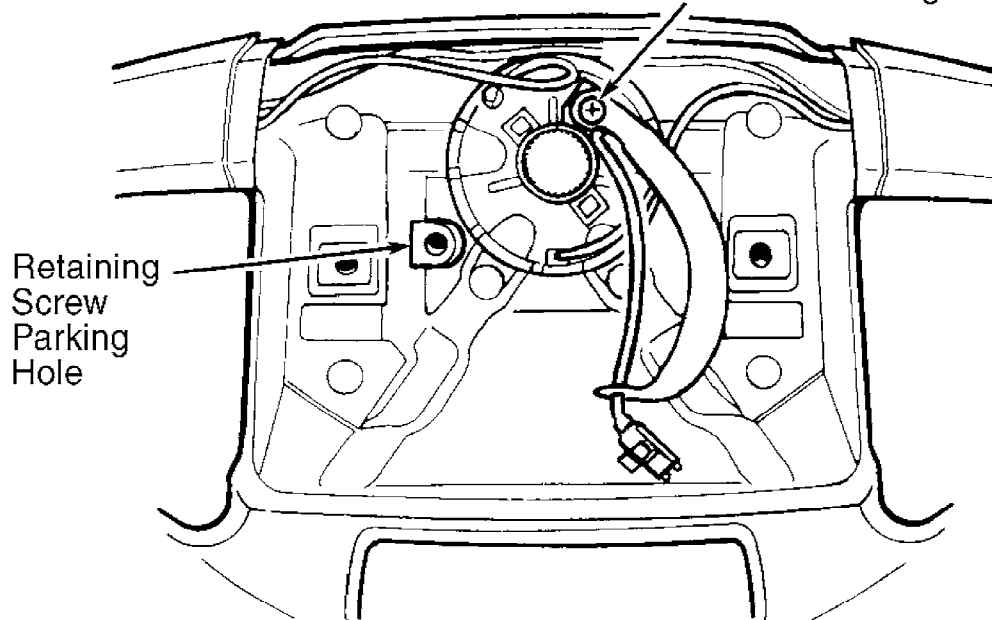

91C01557

Fig. 2: Removing Steering Wheel  
Courtesy of Volvo Cars of North America

COMBINATION SWITCH & WIPER SWITCH

Removal

Remove steering wheel. See STEERING WHEEL & HORN under REMOVAL & INSTALLATION. Remove upper and lower steering column covers. See Fig. 3. Disconnect switch harness connectors behind instrument panel, near steering column. Remove switch attaching screws. See Fig. 3 or 4. Remove switch and harness.

Installation

To install, reverse removal procedure. See STEERING WHEEL & HORN under REMOVAL & INSTALLATION. Ensure all electrical connections are tight. Check turn signal switch canceling.

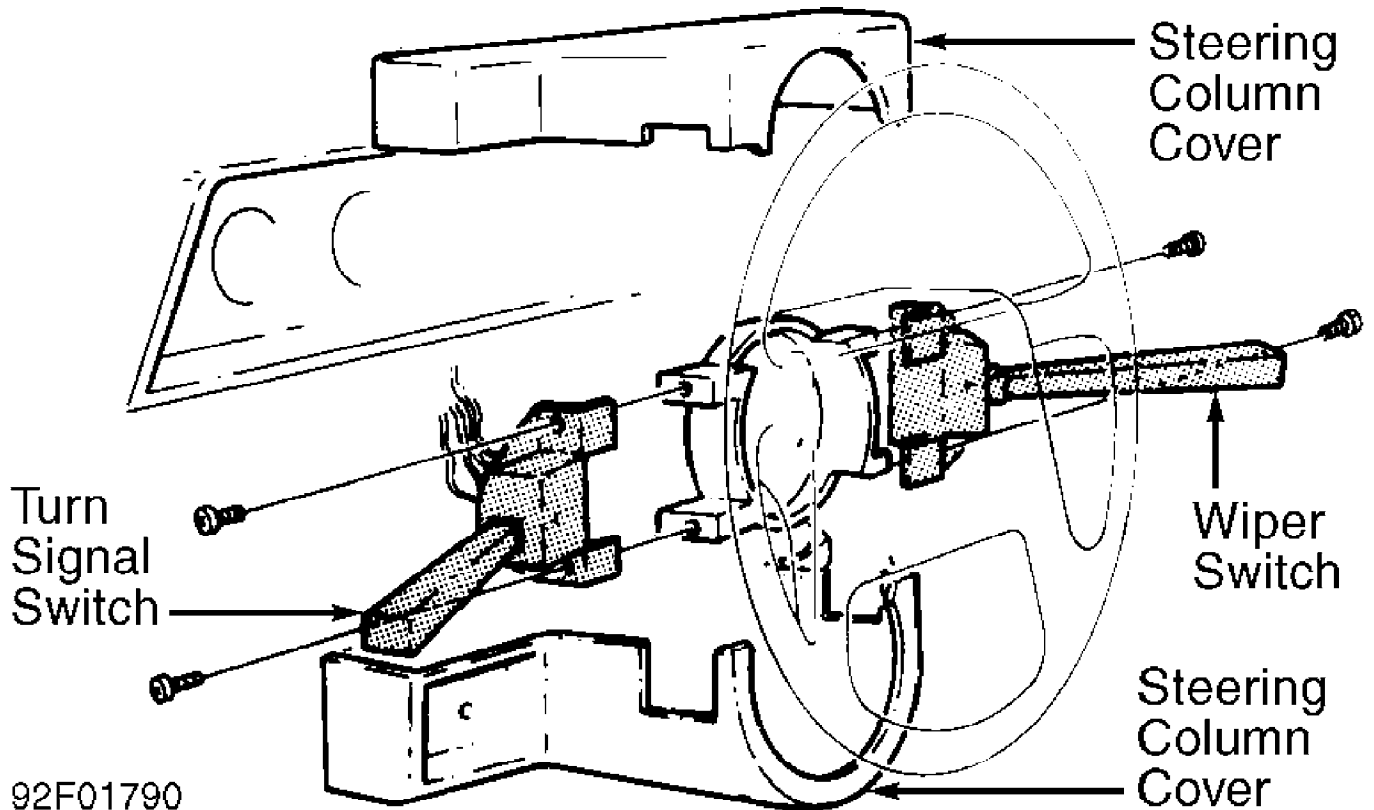

Fig. 3: Removing Upper & Lower Steering Column Covers  
Courtesy of Volvo Cars of North America.

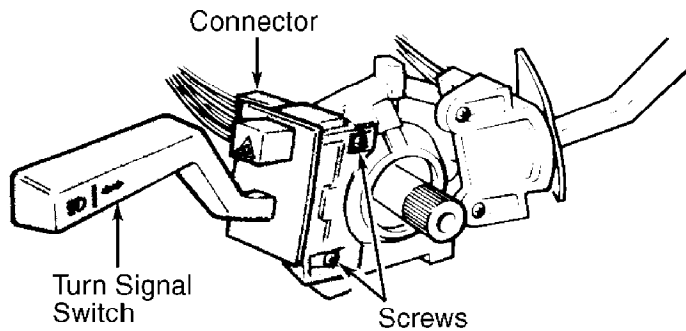
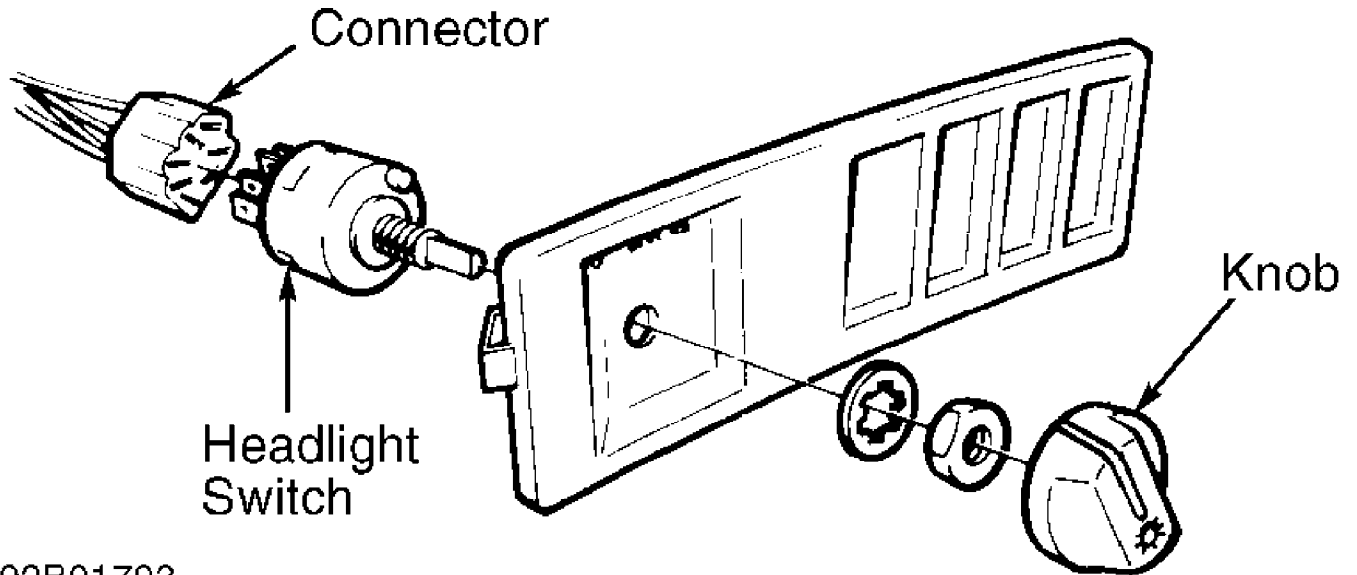

Fig. 4: Removing Combination Switch  
Courtesy of Volvo Cars of North America.

HEADLIGHT SWITCH

#### Removal & Installation

Disconnect headlight connector. Unscrew nut from switch.  
Remove switch. See Fig. 5. To install, reverse removal procedure.



92B01793

Fig. 5: Removing Headlight Switch (Similar)  
Courtesy of Volvo Cars of North America.

#### IGNITION SWITCH & LOCK CYLINDER

##### Removal

Disconnect negative battery cable. Lower steering wheel adjusting lever and pull steering wheel to highest position. Remove upper and lower steering column covers. Insert ignition key into lock. Turn key to position "I". Using a 2-mm drift, press lock cylinder lock lug down. See Fig. 6. Remove lock cylinder.

##### Installation

Insert key into new lock cylinder. Turn key to position "I". Using a 2-mm drift, press lock lug down. Install ignition lock. Install upper and lower steering column covers. Ensure no wires are pinched when covers are installed. To complete installation, reverse removal procedure.

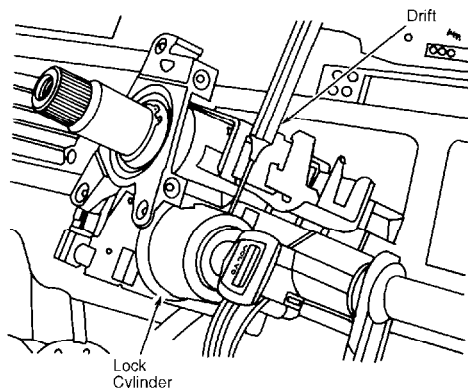

Fig. 6: Removing Ignition Switch Connector  
Courtesy of Volvo Cars of North America.

## TORQUE SPECIFICATIONS

### TORQUE SPECIFICATIONS TABLE

| Application                    | Ft. Lbs. (N.m)  |
|--------------------------------|-----------------|
| Steering Wheel Bolt .....      | 30 (40)         |
|                                | INCH Lbs. (N.m) |
| Air Bag Module Bolts (1) ..... | 90 (10)         |

(1) - Tighten right bolt first.

## WIRING DIAGRAMS

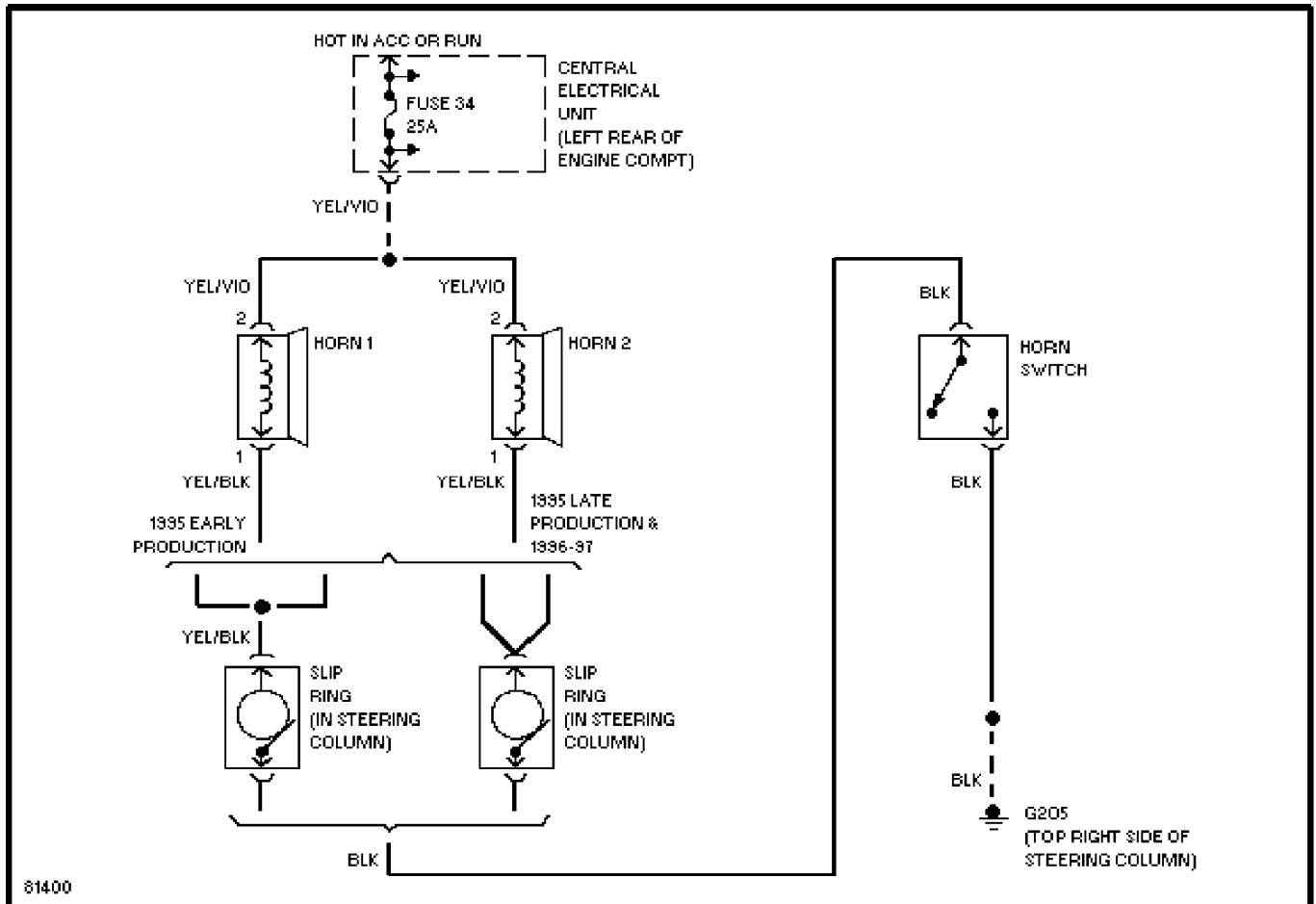

Fig. 7: Horn System Wiring Diagram (1995-96)