

Section	Group	Weight (Kg/Pounds)	Year	Month
8	89		2004	05

---

## Tow bar wiring, 4-pin

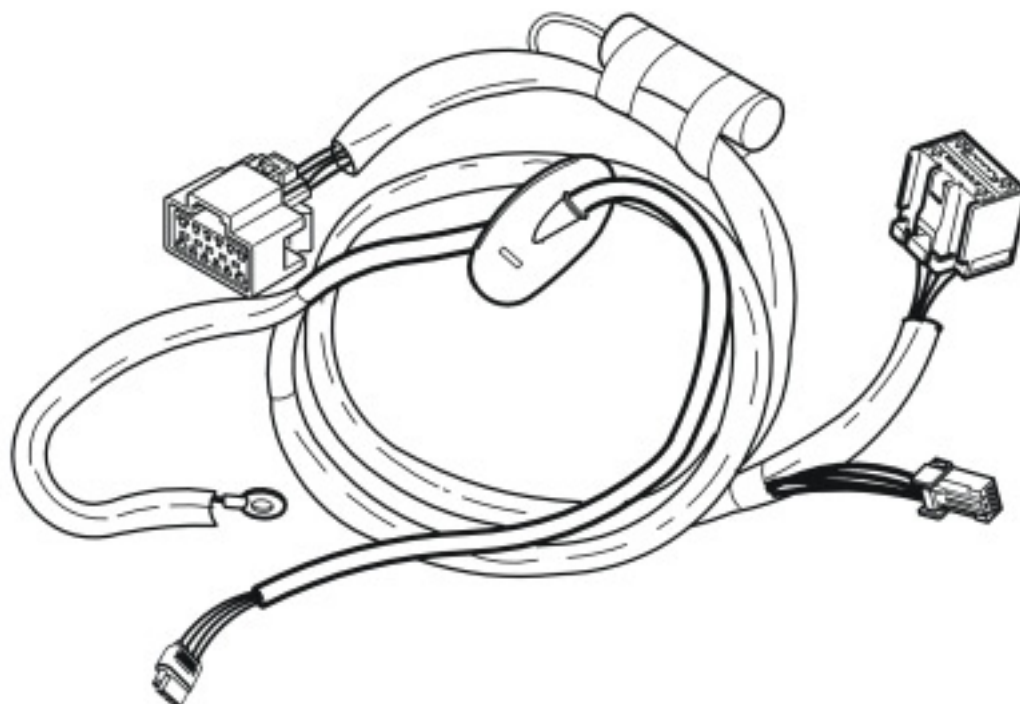

M3905195



A0000162



A0000163

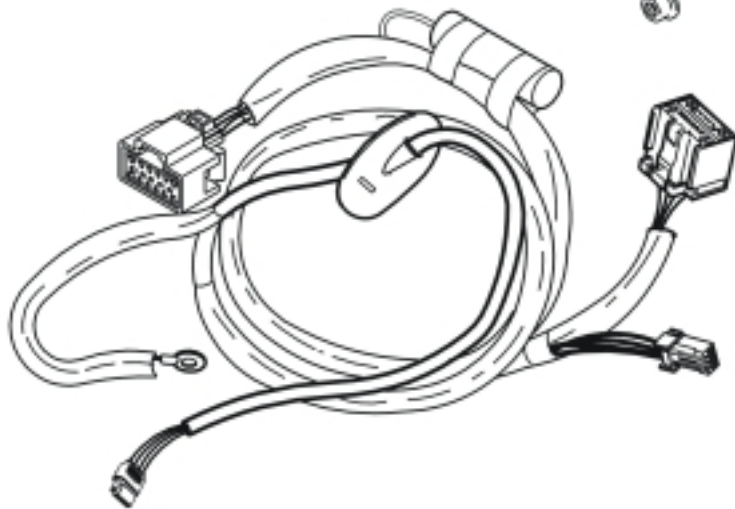
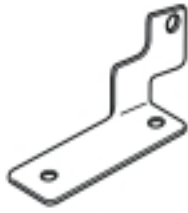
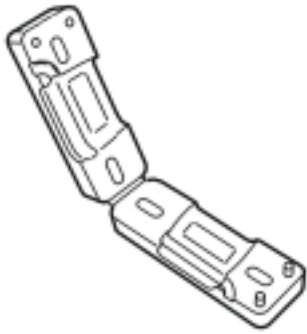

M3905113

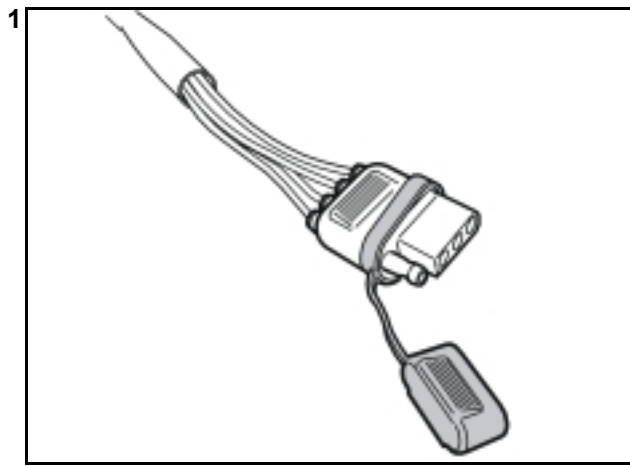

M3904343

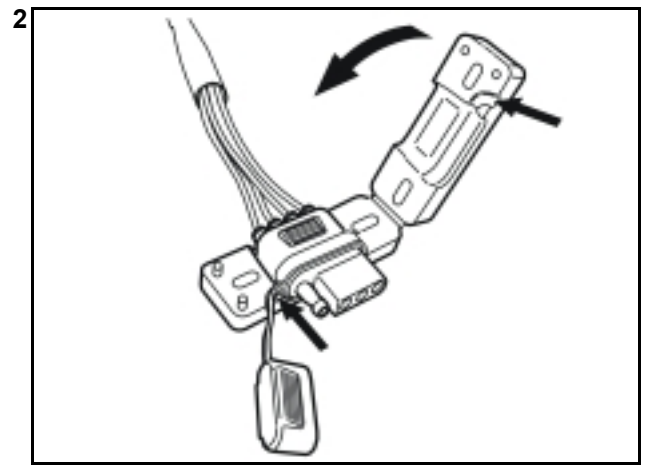

M3904342

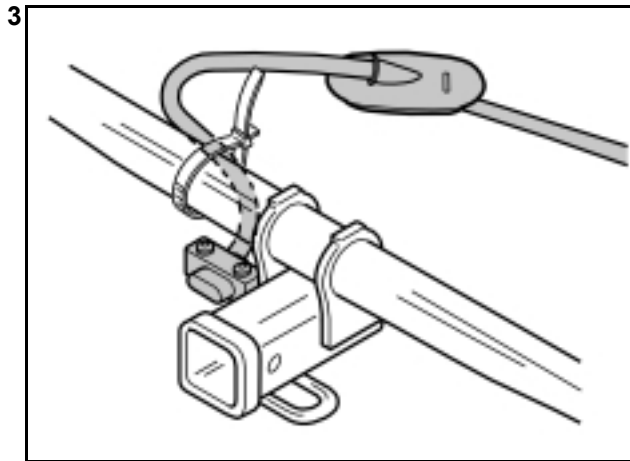

M8903834

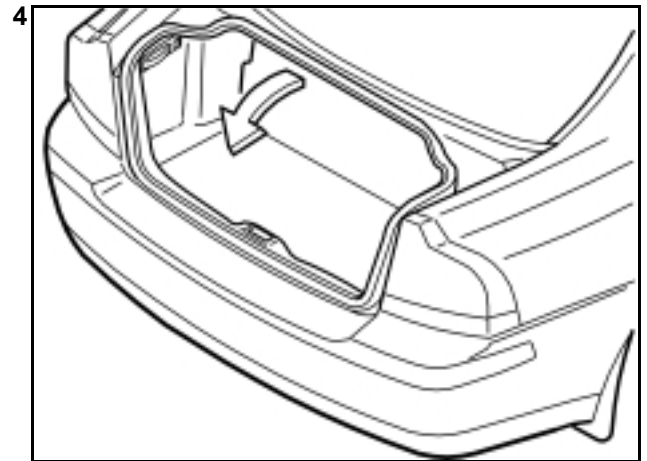

M8503481

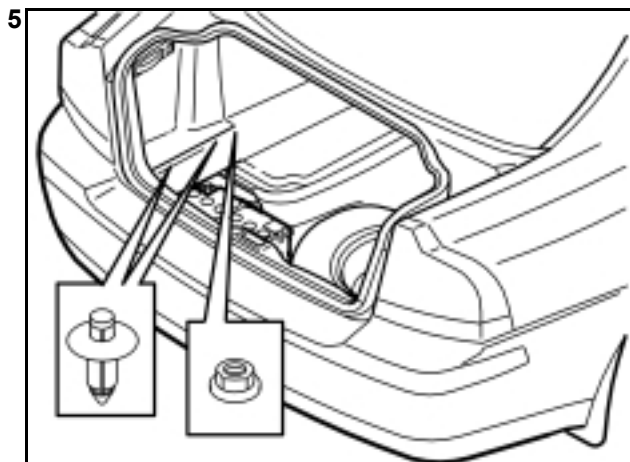

M8902133

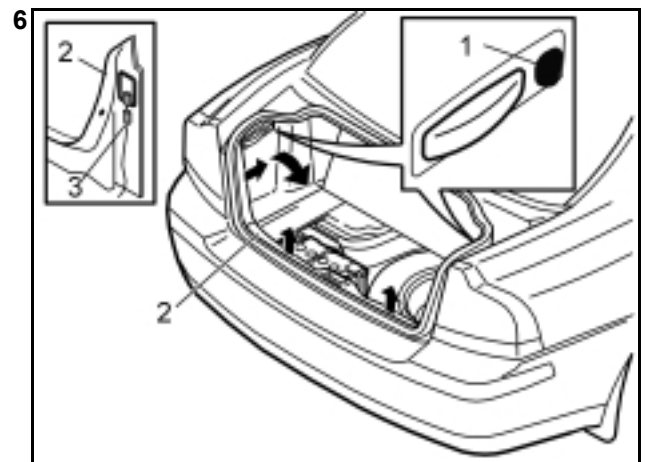

M8503264

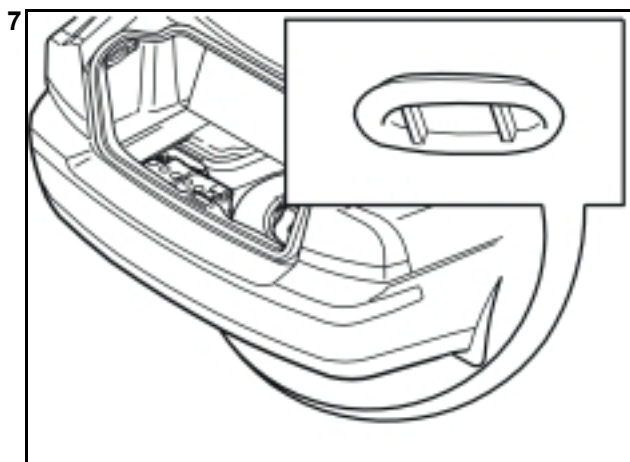

M3100207

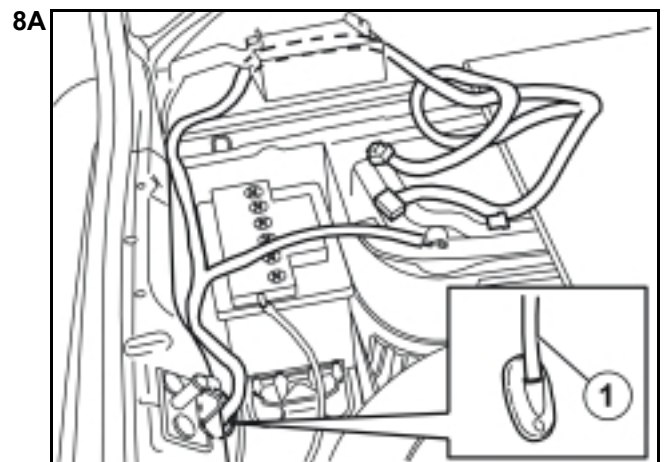

M3100198

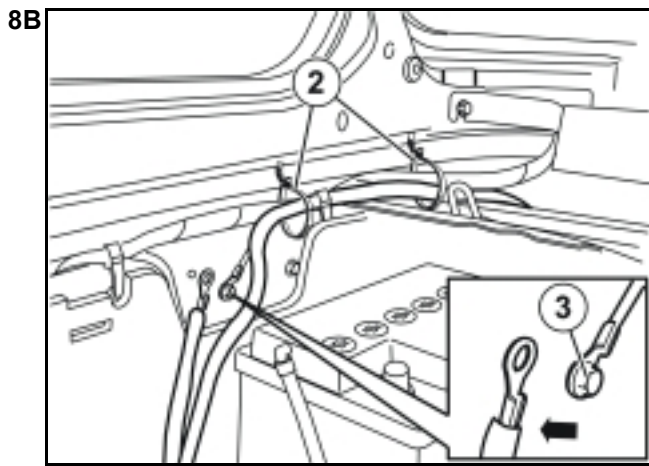

M3100199

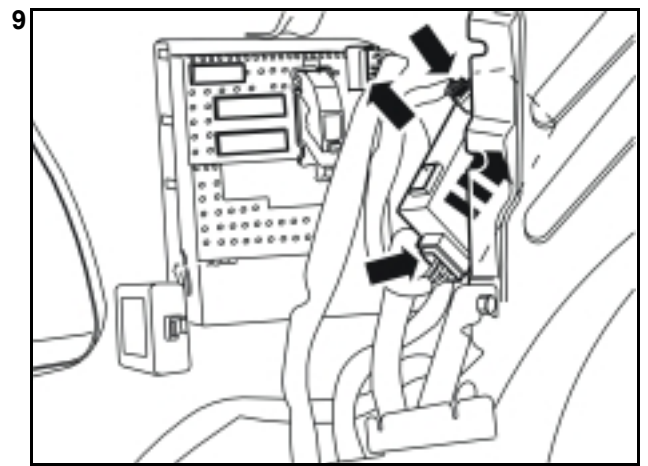

M3905011

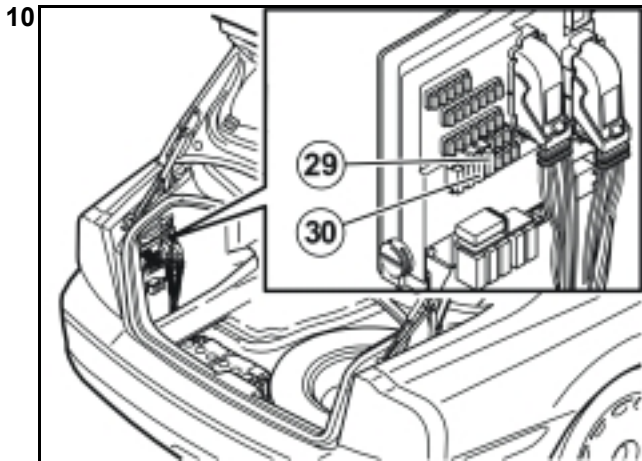

M3703532

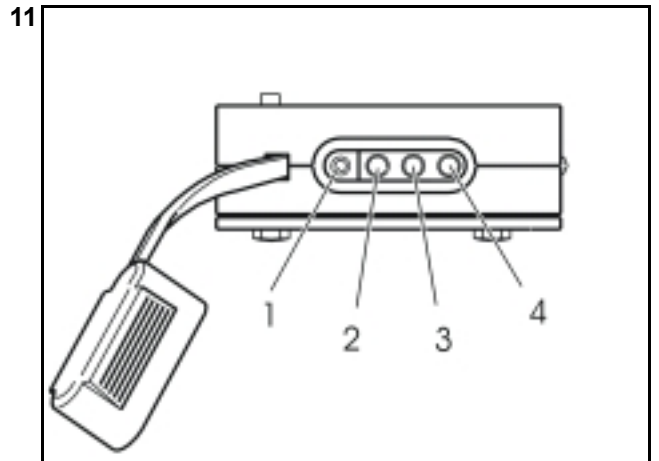

M3703517

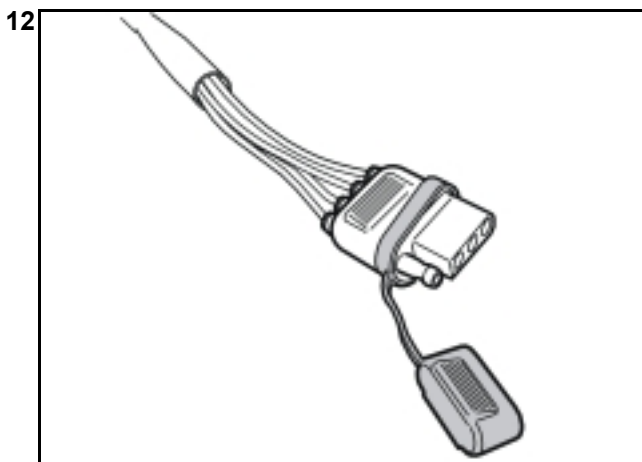

M3904341

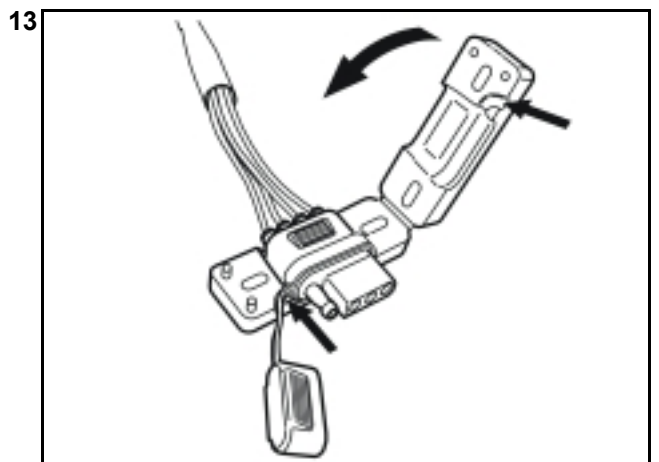

M3904342

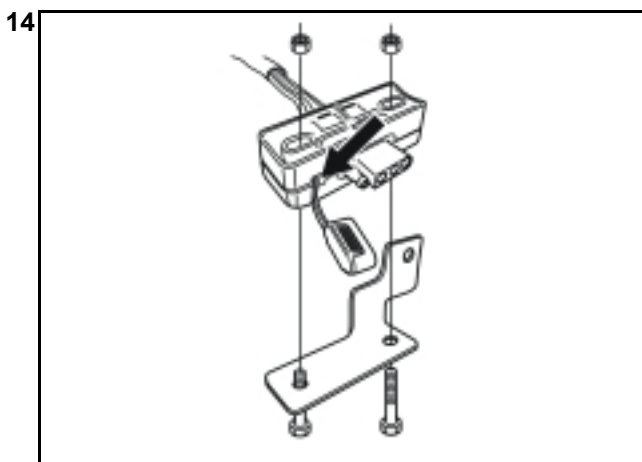

M3904341

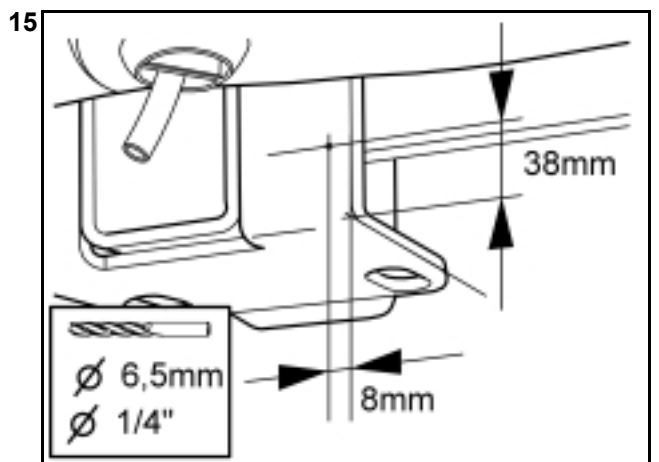

M8902738



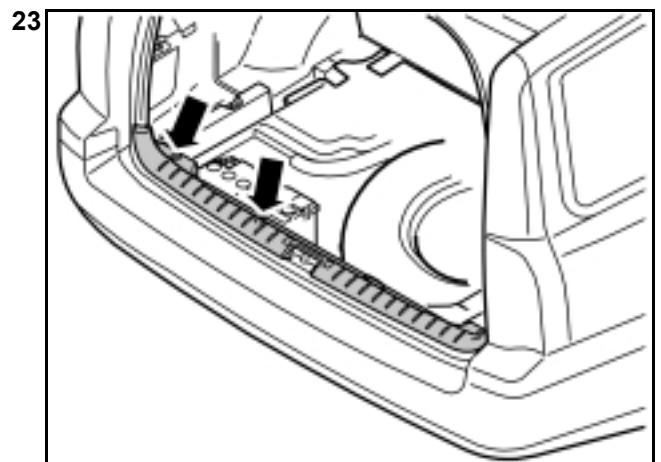
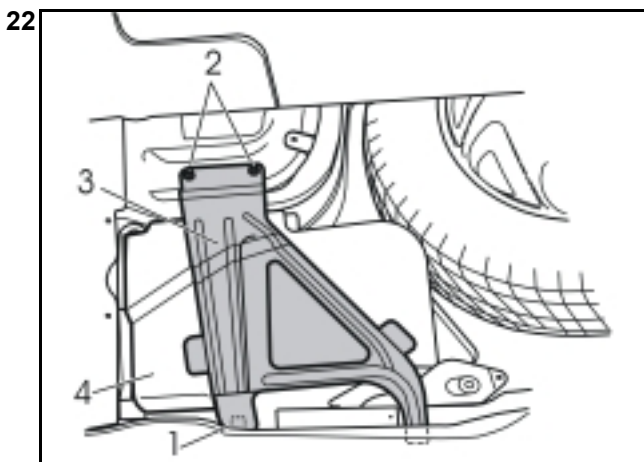
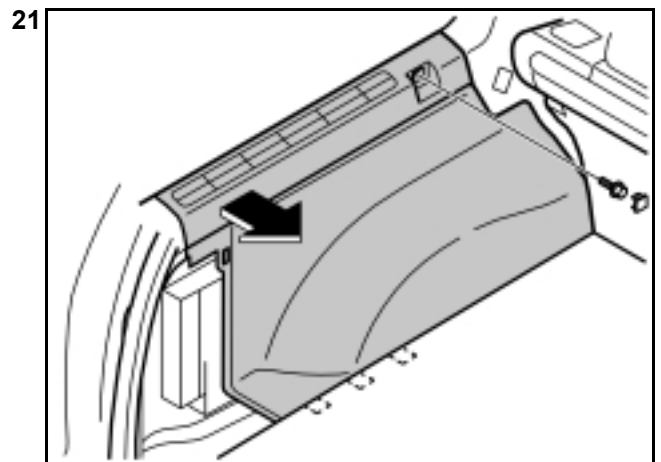
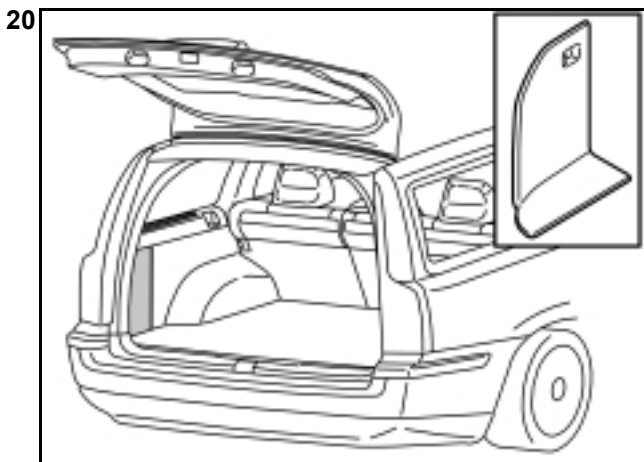
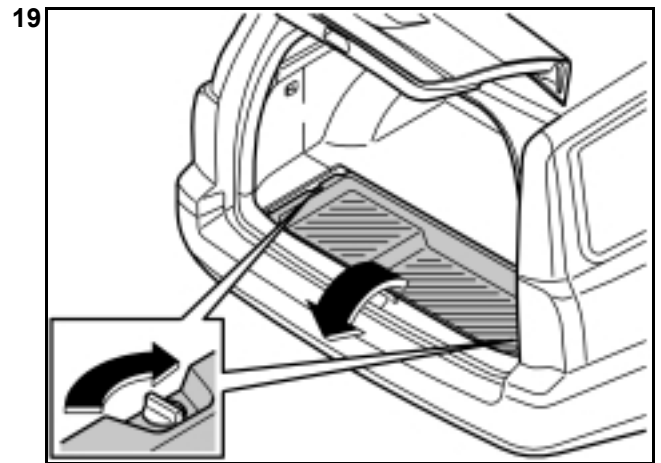
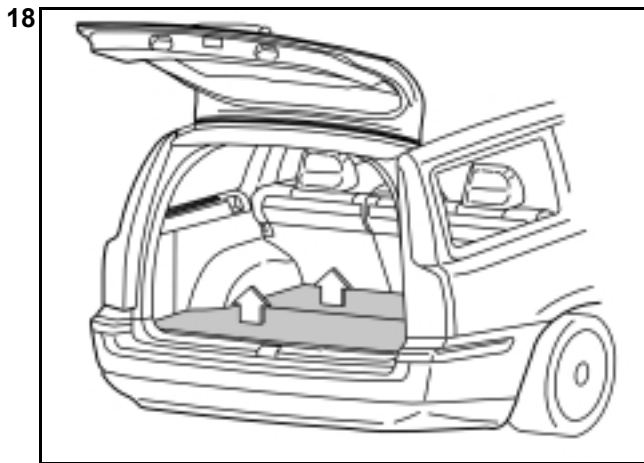
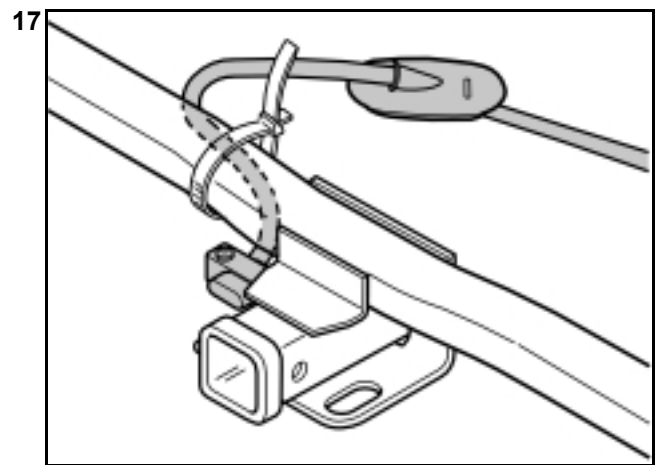
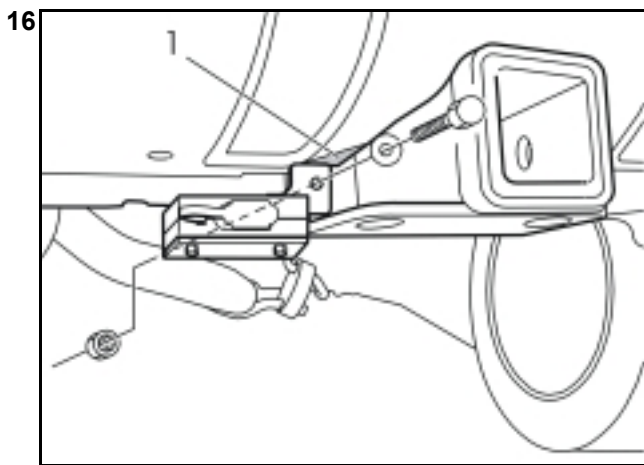

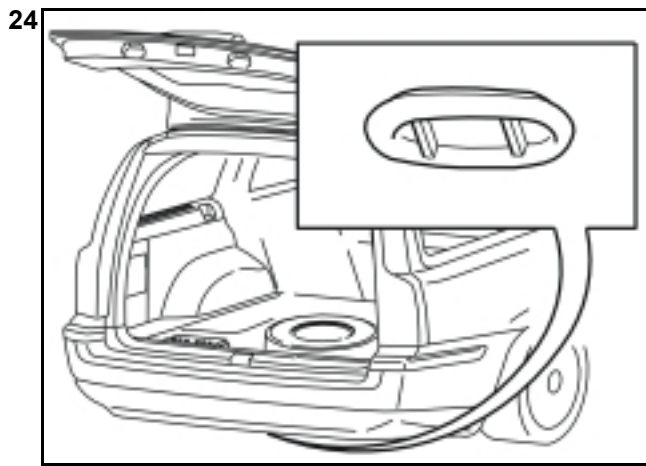

M310077

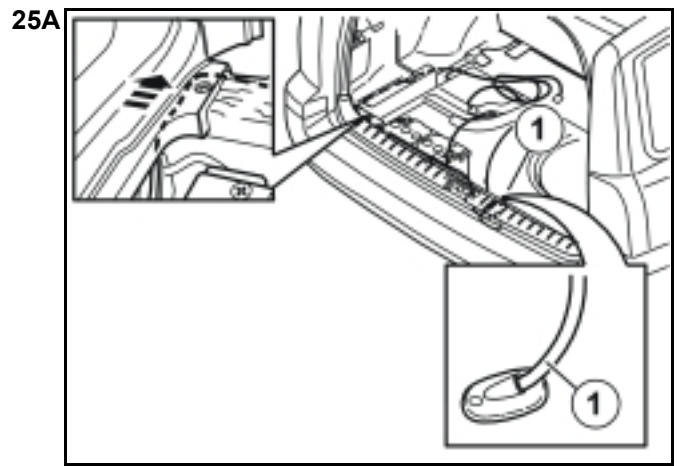

M3100197

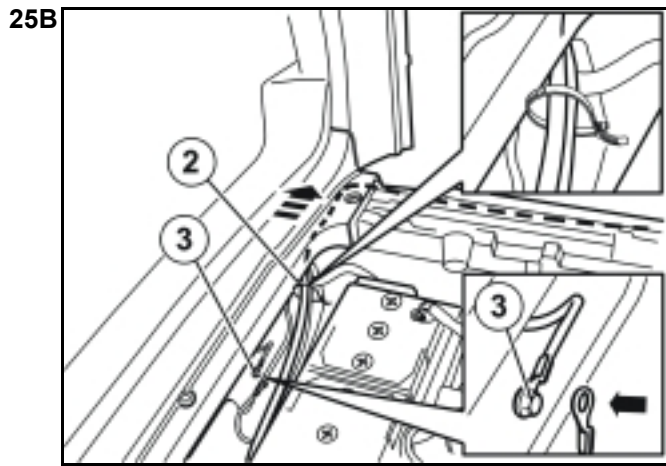

M3100194

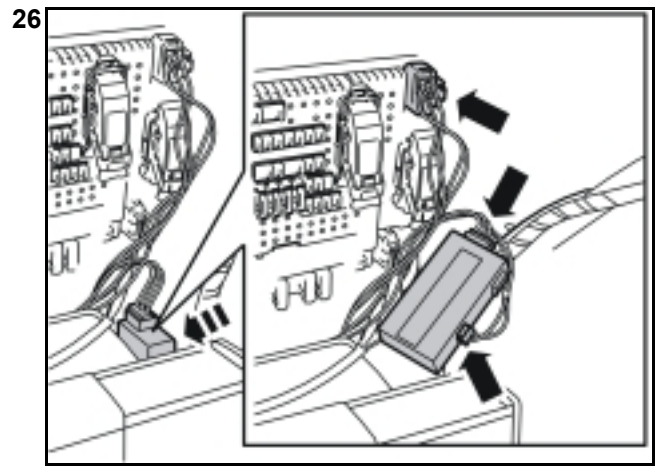

M3603676

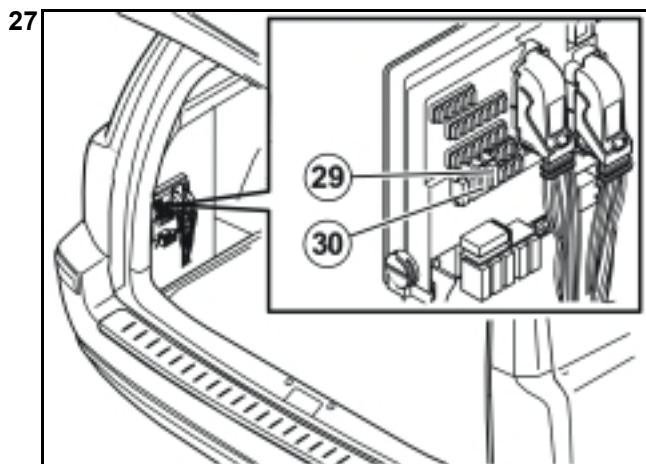

M3703531

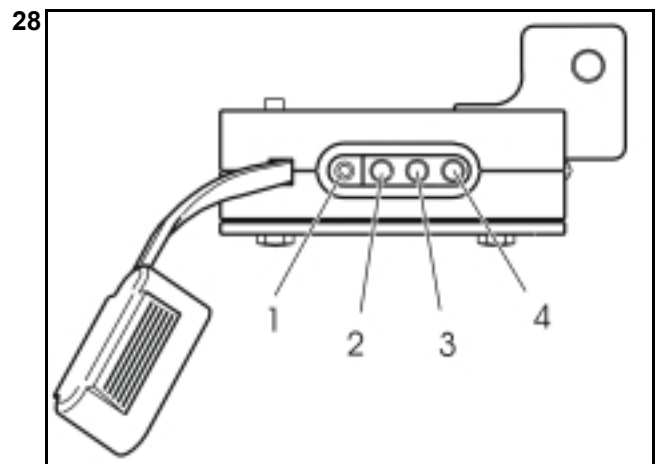

M3703130

# English

## INTRODUCTION

- **NOTE! Read through the entire text before carrying out any work.**
- The front page gives the date of this edition and the edition it replaces
- The second page shows the tools needed for the installation and the contents of the installation kit
- The illustrations display the procedure in order of operation. The order of operation is repeated in the text section
- Cut out the text page in order to follow the illustrations and text at the same time.

## Tow bar wiring, 4-pin

### NOTE!

- Steps 1-11 apply to the S60
- Steps 12-28 apply to the V70

### 1 Steps 1-11 apply to the S60

- Turn the ignition switch to position 0.
- Take the wiring harness and protective cover from the kit.
- Attach the protective cover to the 4-pin connector.

- ### 2
- Take the connector holder from the kit.
  - Place the connector in the holder and press the two halves of the holder together.

**NOTE! Make sure the protective cover retaining strap is not pinched but is positioned in the recess in the connector holder.**

- ### 3
- Take the two smaller bolts and the nuts from the kit.
  - Secure the connector holder with the connector to the bracket.
  - Secure the cable at the towbar member with a tie strap from the kit.

- ### 4
- Remove the carpet from the luggage compartment.

- ### 5
- Press the centre of the clip into the lower edge of the folding side panels on the right-hand and left-hand sides until a click is heard.
  - Remove the two clips.
  - Remove the plastic nut along the front/lower edge of the side panel.

- ### 6
- Turn the knob (1) on the right-hand and left-hand sides 90°.
  - Fold the panels inwards. Lift the panels out.
  - First, pull the bootlid sill trim panel (2) forwards until the two clips on the right-hand and left-hand sides release. Pull forcefully but carefully since the panel is fitted tightly. Pull the panel straight up until the four clips in the lower edge release.
  - Remove the wiring (3) for the cargo compartment lighting.
  - Lift out the sill trim panel.

- ### 7
- Remove the dummy plug from the hole in the body (battery draining is not affected).

### 8 Illustration A

- Route the cable harness from the tow bar connector through the hole in the floor.
- Adjust the position of the rubber seal (1) so that there is not excessive cable slack under the car.
- Install the rubber seal in the hole.
- Route the cable harness over the rear edge of the left-hand side member to the fuse holder as illustrated.

### Illustration B

- Secure the cable harness to the cable harness behind the battery with tie straps (2) from the kit.
- Connect the routed ground cable to the grounding point (3) behind the battery and tighten the grounding screw securely.

- ### 9
- Detach the trailer module (TRM) from the Velcro fastener on the back side of the plate in front of the fuse holder.
  - Plug in the tow bar wiring connectors:
    - green (GN) and grey (GR) connectors to the control module.
    - black (SB) connector to the fuse holder.
  - Reinstall the control module.
  - Secure the excess cable with a tie strap from the kit.

- ### 10
- Insert fuses from the kit in the following positions in the fuse holder (REM):
    - 25A in position 29
    - 25A in position 30.
  - Plug in the connectors for sill trim panel lighting and reinstall the panel.
  - Reinstall the folding panels.
  - Reinstall the cargo compartment carpet.

- 11**
- 1 Ground
  - 2 Parking lamps
  - 3 Brake lamp / Left-hand indicator lamp
  - 4 Brake lamp / Right-hand indicator lamp
- 12** **Steps 12-28 apply to the V70**
- Turn the ignition switch to position 0.
  - Take the wiring harness and protective cover from the kit.
  - Attach the protective cover to the 4-pin connector.
- 13**
- Take the connector holder from the kit.
  - Place the connector in the holder and press the two halves of the holder together.
- NOTE! Make sure the protective cover retaining strap is not pinched but is positioned in the recess in the connector holder.**
- 14**
- Take the bracket, the two smaller bolts and the nuts from the kit.
  - Secure the bracket to the connector holder.
- 15**
- Mark the location of the drill hole for the connector bracket as illustrated.
  - Pre-drill with a smaller drill bit. Enlarge the hole with a **Ø6.5 mm (1/4")** drill bit.
  - Remove any swarf. Rust-proof the edges of the holes.
- 16**
- Take the bolt, nut and washer from the kit.
  - Place the bracket with the connector over the drilled hole.
  - If the bracket does not fit: Mark an area on the bumper cover where the corner (1) should be cut away and remove the section. If the car is equipped with a protective plate on the rear bumper, it may require chamfering.
  - Secure the bracket to the towbar member.
- 17**
- Secure the cable at the towbar member with a tie strap from the kit.
- 18**
- Remove the two floor hatches in the cargo compartment.
- 19**
- Remove the storage compartment under the rear floor hatch by turning the clips on the right-hand and left-hand sides 90°. Lift out the compartment.
- 20**
- Remove the left-hand folding panel in the cargo compartment.
- 21**
- Remove the left-hand side panel by first removing the cover and screw from the front edge.
  - Pull the top edge of the panel out until the clips release.
  - Fold the panel inwards. Lift the panel out.
- 22** **Applies only to cars with the extra seat or subwoofer accessories**
- Remove the bolt (1) and the nuts (2).
  - Remove the bracket (3) by pulling it forward.
  - Lift off the protective cover (4).
- 23**
- Remove the two screws in the tailgate sill trim panel.
- 24**
- Remove the dummy plug from the hole in the body (battery draining is not affected).
- 25** **Illustration A**
- Route the cable harness from the tow bar connector through the hole in the floor.
  - Adjust the position of the rubber seal (1) so that there is not excessive cable slack under the car.
  - Install the rubber seal in the hole.
  - Route the cable harness as shown in the illustration. Pull up the sill trim panel on the left-hand side and place the cable harness in the space behind the left-hand floor support. Make sure the cable harness is not pinched before reinstalling the sill trim panel.
  - Tighten the sill trim panel securely.
- Illustration B**
- Secure the cable harness to the cable harness behind the battery with a tie strap (2) from the kit.
  - Connect the routed ground cable to the grounding point (3) behind the battery and tighten the grounding screw securely.
- 26**
- Detach the trailer module (TRM) from the front edge of the cover on the ventilation opening along the rear edge of the left-hand rear wheel housing.
  - Plug in the tow bar wiring connectors:
    - green (GN) and grey (GR) connectors to the control module
    - black (SB) connector to the fuse holder
  - Reinstall the control module.
  - Secure the excess cable with a tie strap from the kit.



- 27** – Insert fuses from the kit in the following positions in the fuse holder (REM):
- 25A in position 29
  - 25A in position 30.
- Reinstall the side panel.
  - Reinstall the folding panel.
  - Reinstall the battery cover and bracket if applicable.
  - Reinstall the storage compartment and floor hatches.

- 28**
- 1 Ground
  - 2 Parking lamps
  - 3 Brake lamp / Left-hand indicator lamp
  - 4 Brake lamp / Right-hand indicator lamp