

Section	Group	Weight (Kg/Pounds)	Year	Month
8	89		2002	05

Tow hitch wiring, 7/4-pin

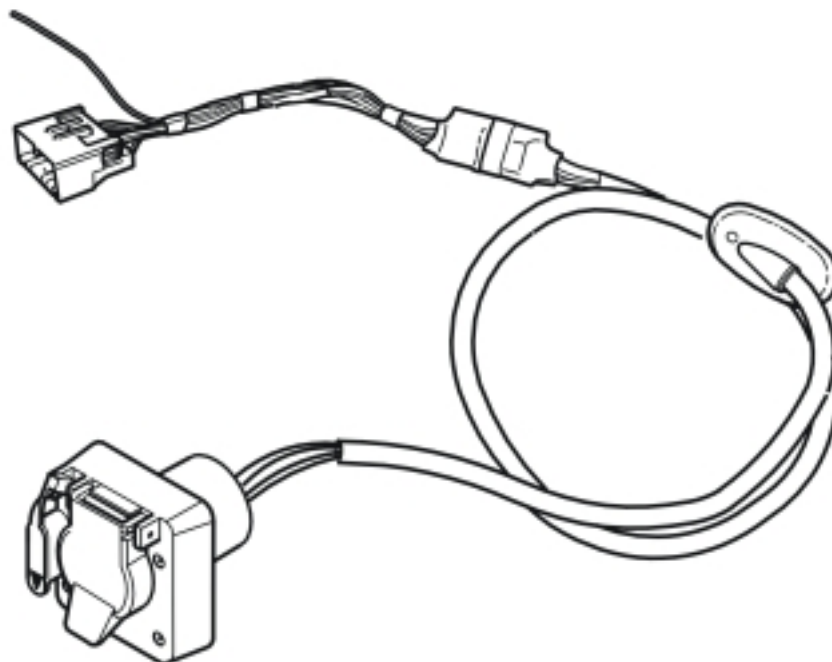

R3703052



A0000162



Nm
lbf.ft

A0000161

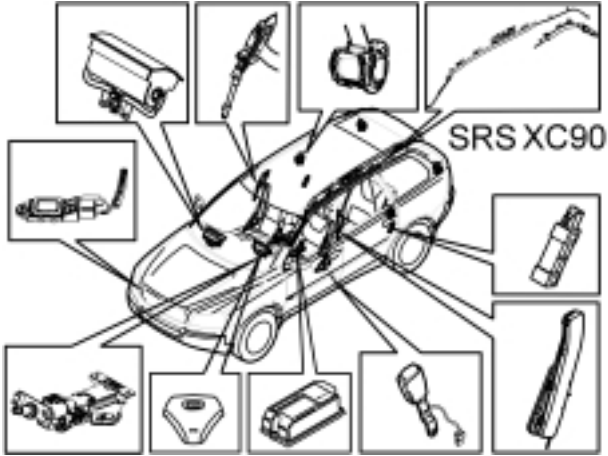

SRS XC90

R8802817

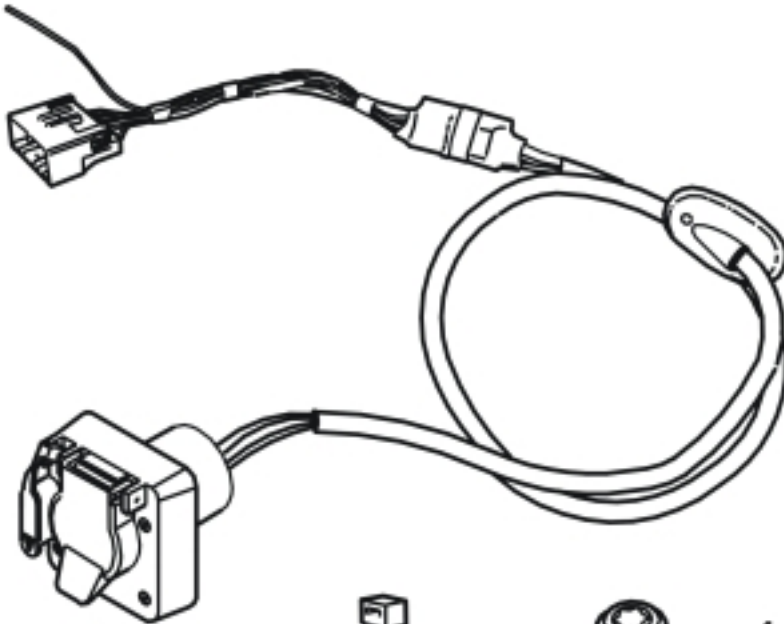

20A

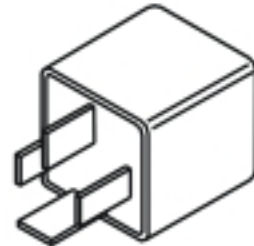

x4



x4



x4

M3703112

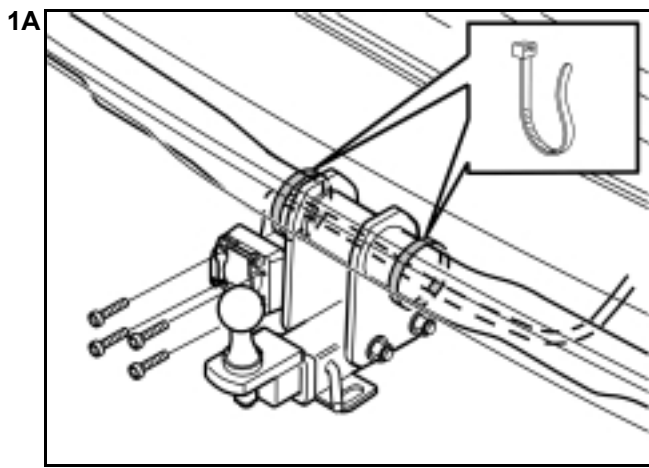

R8903025

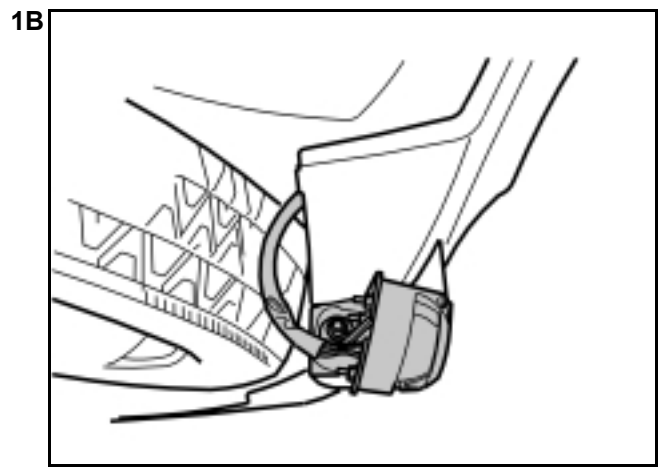

R8903038

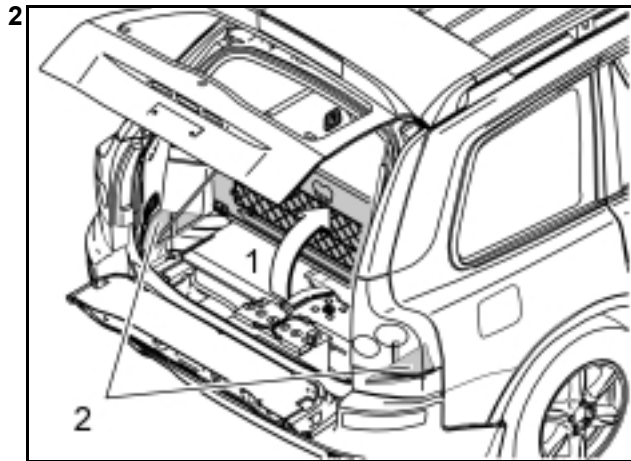

R8902382

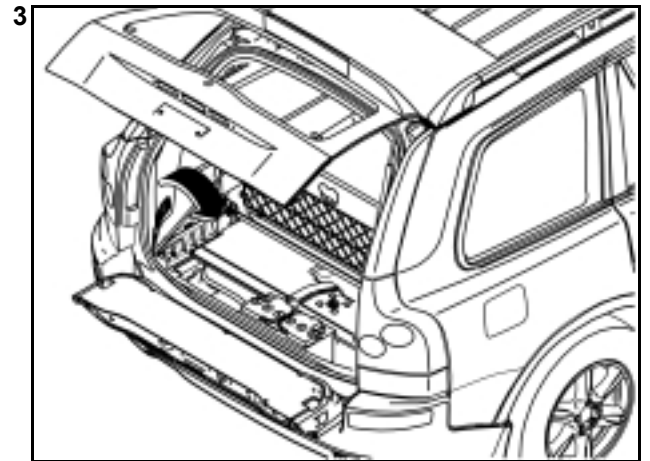

R8902766

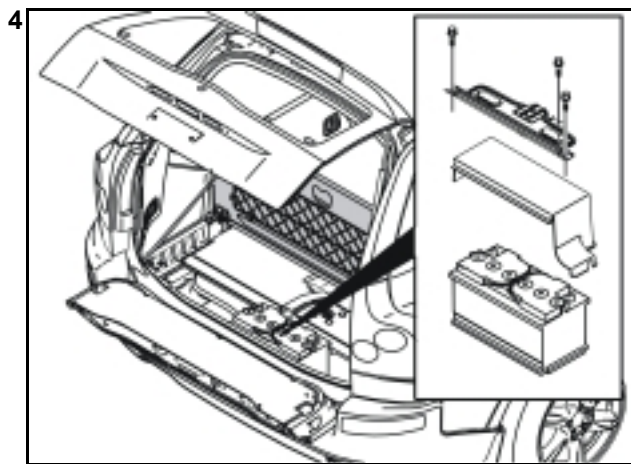

R3100130

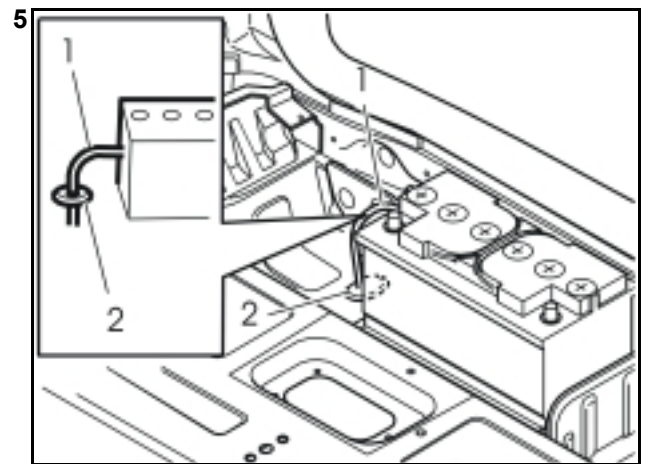

R3100141

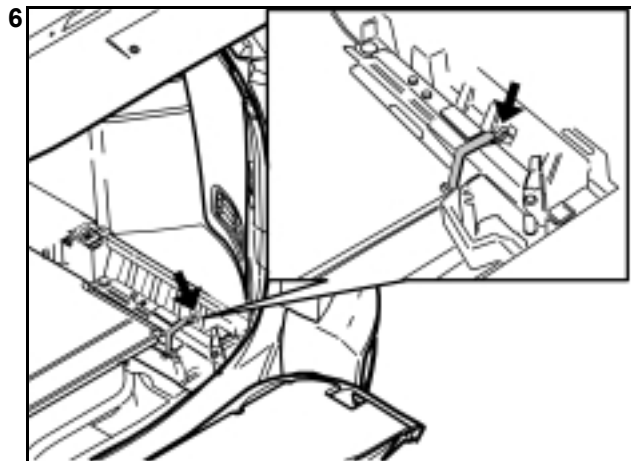

R8902823

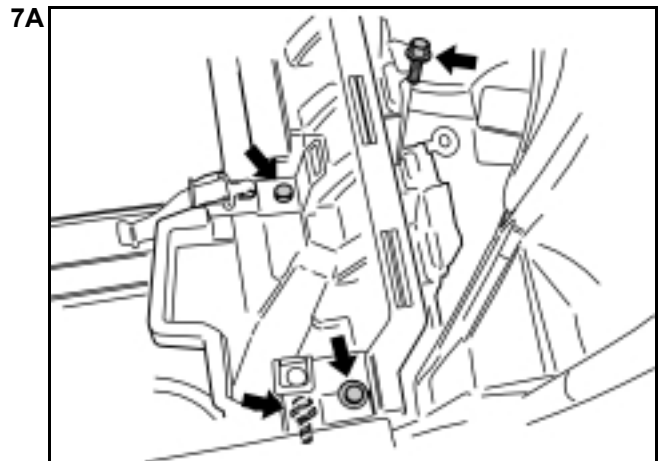

R8903022

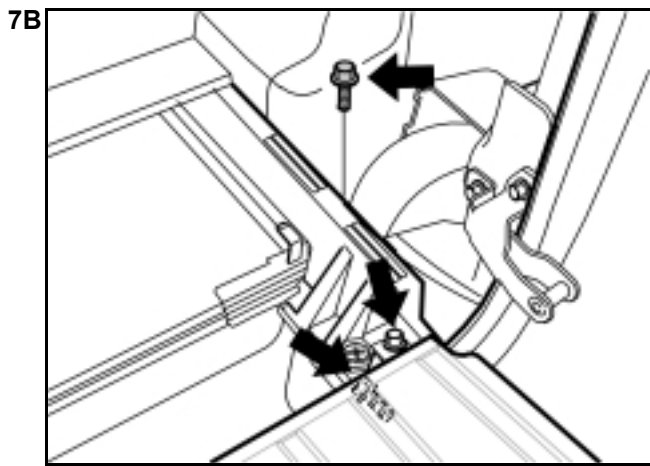

R8903087

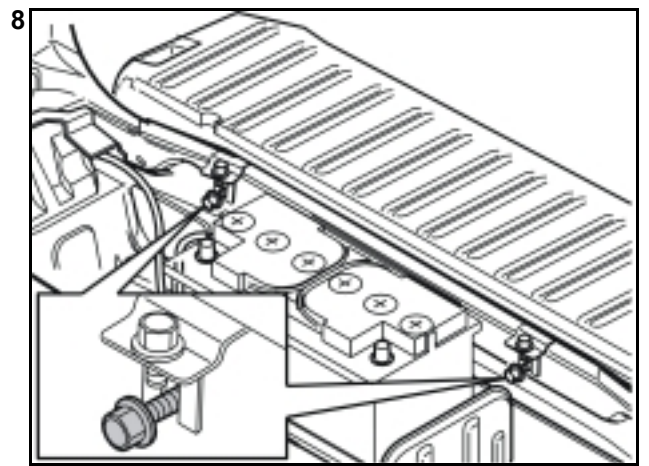

R3100168

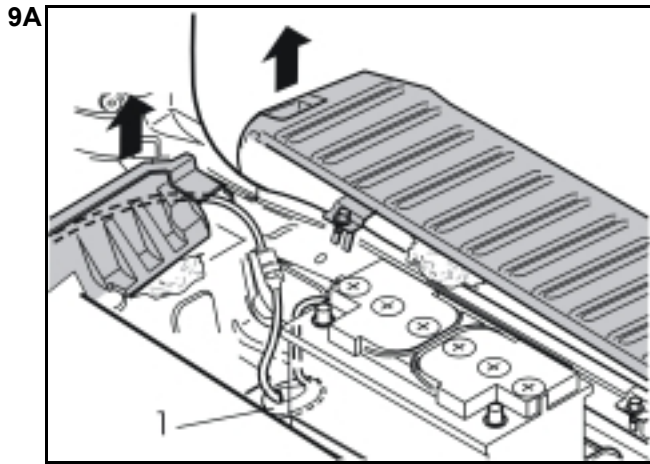

R3100168

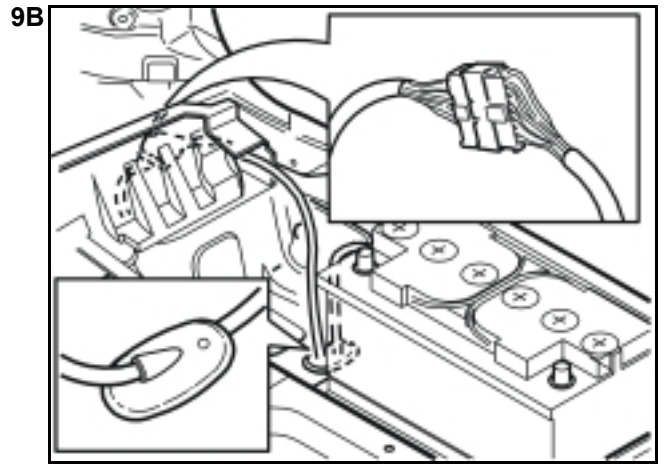

R3903744

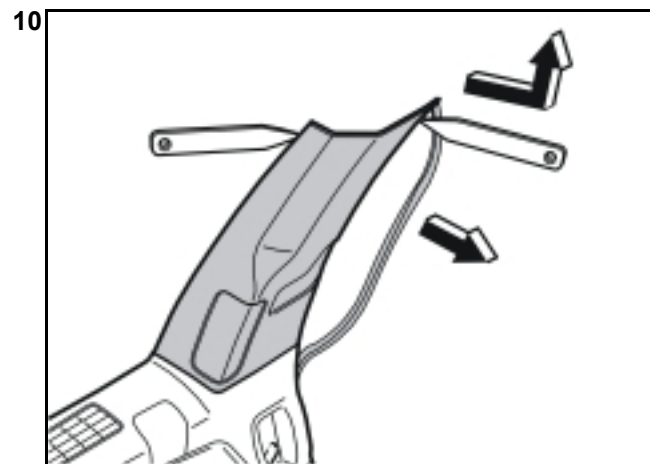

R3903738

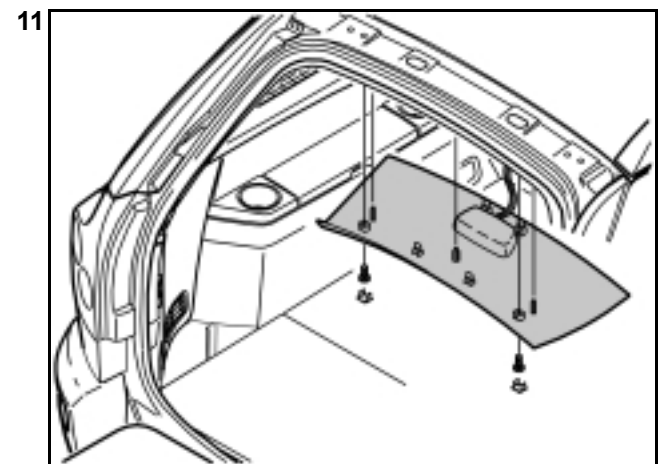

R8504201

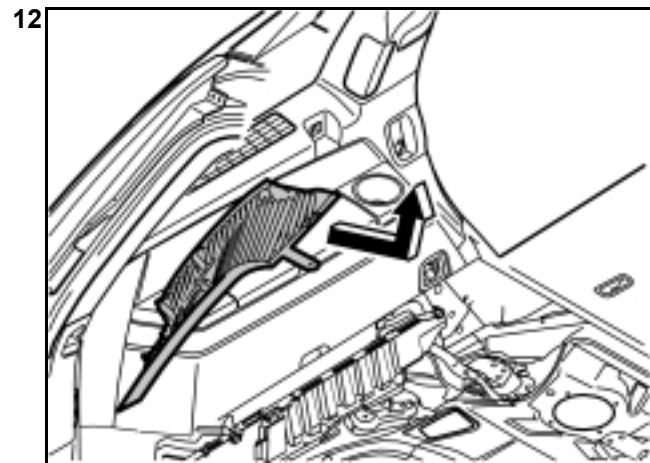

R8504123

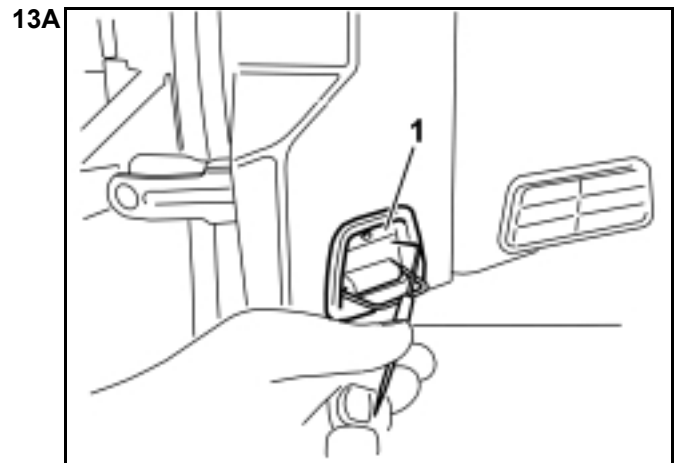

R8504313

13B

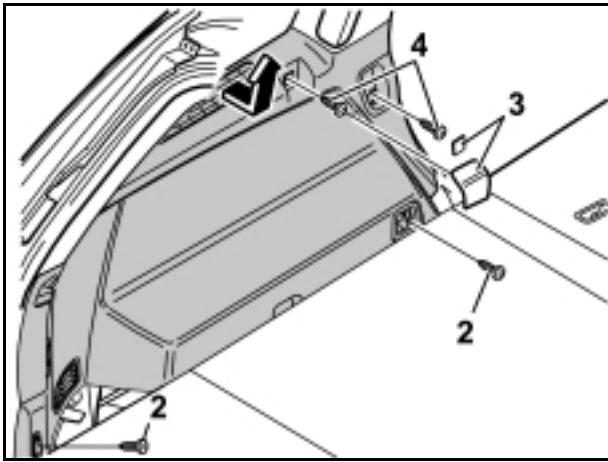

R8504315

13C

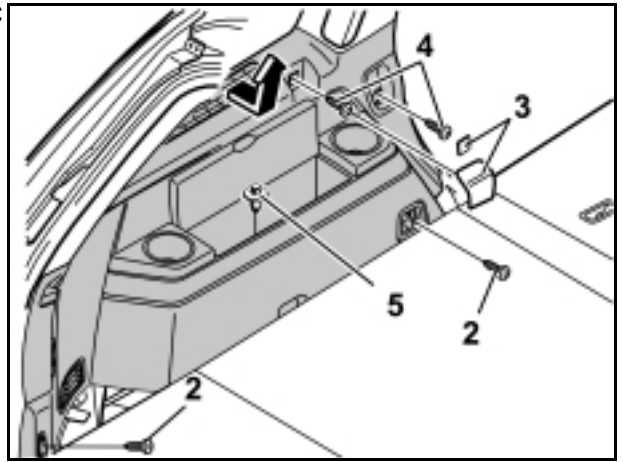

R8504316

14

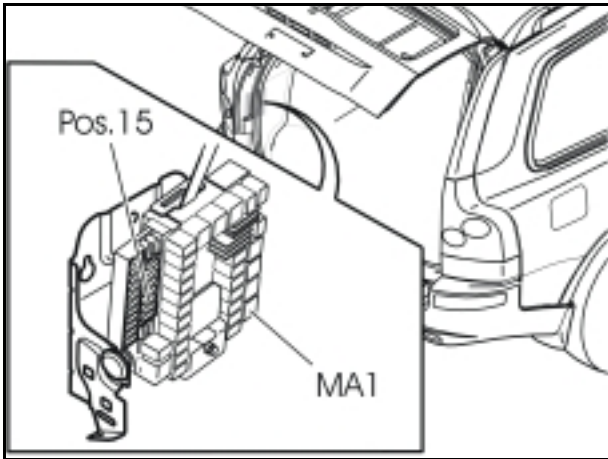

R3703113

16

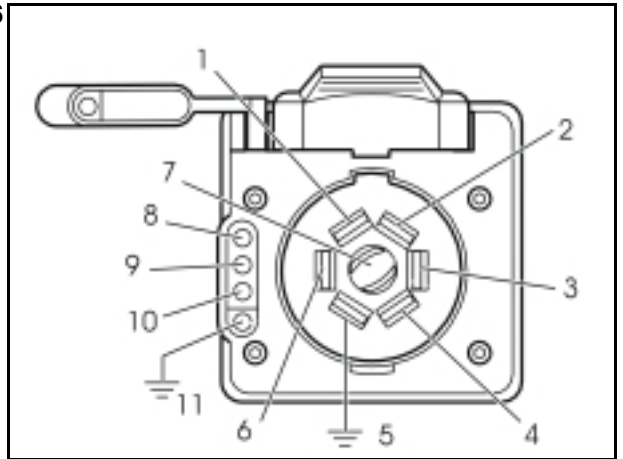

R3703054

English

INTRODUCTION

- **NOTE! Read through the entire text before carrying out any work.**
- The front page gives the date of this edition and the edition it replaces
- The second page shows the tools needed for the installation and the contents of the installation kit
- The illustrations display the procedure in order of operation. The order of operation is repeated in the text section
- Cut out the text page in order to follow the illustrations and text at the same time.

Cars equipped with SRS/SIPS (Airbag)

WARNING! Extra care must be taken when working on cars equipped with SRS/SIPS air bags. This is important to prevent:

1. Personal injury
2. Damage to or malfunction of the SRS/SIPS system.

Work on the SRS/SIPS systems or related components must always be carried out by an authorised Volvo workshop.

Is the car equipped with SRS (supplemental restraint system)?

Cars equipped with a driver's airbag have the letters "SRS" imprinted on the centre panel of the steering wheel. Cars equipped with driver's and passenger airbags are marked with "SRS" on both the steering wheel centre panel and also on the dashboard close to the airbag.

If the car is equipped with SIPS (side impact protection system) a "SIPS" decal is marked on both the front seats.

Cars equipped with inflatable curtains have the marking "SRS" on one of the panels along the posts on the inside of the car.

Cars equipped with SRS (supplemental restraint system) also have a "SRS" decal on the front windscreen.

Do not damage the SRS wiring!

Do not trap, fray, pierce or damage the SRS wiring. SRS wiring has orange casing and/or is plaited.

Steering and front suspension

The contact reel in the SRS system can easily be damaged when working on the steering wheel, steering shaft or steering gear. Refer to the SRS (supplemental restraint system) Service Manual or service instructions in VIDA for information on carrying out such work. This is to prevent damage.

SRS warning lamp

If the SRS warning lamp lights after repairs have been carried out, take the car to an authorised Volvo workshop.

SRS collision sensor control module

S60 / V70 (00-) / S80 / XC90

The collision sensor control module is located on the transmission tunnel in the centre console, in front of the parking brake.

WARNING!

The air bag inflation areas must not be obstructed. Never place any objects, such as upholstery or accessories, within these areas. The panels must be able to deploy in the correct manner at the right time otherwise there is a risk of personal injury in the event of a collision.

WARNING!

The ignition must be in position "0" and the key removed from the ignition if any connector in the SRS system is to be disassembled. Then wait at least one minute. Then disconnect the battery negative lead before disassembling any of the connectors. When work is completed the ignition key must be turned to position "II" before reconnecting the battery negative lead.

Tow hitch wiring, 7/4-pin

NOTE! The relay and fuses are not included in the kit.

Installing the tow hitch connector

- 1 – Install the tow hitch connector using the four screws and nuts. Tighten
- Route the cable harness to the right along the front edge of the tow hitch member. The cable harness is routed the same way regardless of the type of tow hitch
- Secure the cable harness using a tie strap on each side of the brackets for the tow hitch member.
-

NOTE! If the cable harness is stretched too far it may be worn through by the lower edge of the bumper.

Ensure that the cable harness forms a small loop around the lower edge of the bumper as illustrated in illustration B.

- 2 Applies to cars with two rows of seats**
- Fold up the centre rear floor hatch (1). If the floor hatch is equipped with a carrier bag holder on its underside, it secured by a strap on each of the shorter sides of the storage box. These must be removed
 - Remove the storage box underneath
 - Remove the floor hatch completely by folding it almost all the way down and pulling it out backwards from its mountings.

Applies to cars with three rows of seats and integrated carrier bag holder on the underside of the centre floor hatch

- Fold up the centre rear floor hatch (1)
- Detach the two straps from the panel underneath. Lift up the rear edge of the panel. Fold the floor hatch back towards the panel and lift out the floor hatch and the panel.

Applies to cars with three rows of seats without integrated carrier bag holders

- Fold up the centre rear floor hatch (1) at the rear edge and lift it out.

Applies to all models

- Remove the right and left-hand side floor hatches (2).

- 3** – Remove the folding side panel on the left and right-hand sides of the cargo compartment.

- 4** – Remove the three screws in the battery holder. Lift out the battery holder
- Remove the cover from the battery.

- 5** – Remove the drainage hose (1) from the battery
- Remove the rubber seal (2). This will not be used again
 - Open up the pre-punched hole for the drain hose in the new rubber bushing
 - Thread the old drainage hose through the new rubber bushing. Ensure that the hose is unimpeded and is not kinked.

Cable routing and connection

- 6 Applies to cars with two rows of seats**
- Release the tensioning strap for the jack and lift it out.

- 7 Illustration A applies to cars with two rows of seats**

Illustration B applies to cars with three rows of seats

- Remove the screws holding the support for the floor in the cargo compartment at the rear edge.

- 8** – Slacken off the two screws for the floor extension brackets.

9 Illustration A

- Route the cable harness from the tow bar socket through the hole in the floor. It may be necessary to remove the spare wheel which partially obstructs the hole in the floor
- Adjust the position of the rubber seal (1) so that there is not too much slack in the cable under the car
- Install the rubber seal in the hole
- Pull up the floor extension on the right-hand side. Position a shim underneath it

- Pull up the rear edge of the support for the floor in the cargo compartment. Push the connector into the space behind the right-hand rear wheel well.

NOTE! Do not damage the support for the floor in the cargo compartment. It is brittle.

- Position the cable in the cut-out at the rear edge of the support for the floor in the cargo compartment. Reinstall the support for the floor and the floor extension in the cargo compartment
- Tighten the support for the floor in the cargo compartment and floor extension. **Applies to cars with two rows of seats:** Reinstall the jack.

Illustration B

- Connect the routed cable harness to the existing cable harness in the space
- Pull the excess cable into the small space. Secure everything to the existing cable harness using the tie straps from the kit. Ensure that the connectors are secured so that they do not rattle
- Reinstall the drain hose on the battery.

Connecting the positive power supply / charge function

- 10** To connect the positive power supply / charge function, remove the side panel on the left-hand side of the cargo compartment in order to access the rear fusebox.

- Pull off the rubber strip at the rear edge of the door opening to the left-hand rear door opposite the left C-post panel
- Carefully pry off the left-hand C-post panel sides at the top using a plastic weatherstrip tool Then pull until the three clips on the inside release.

NOTE! Do not damage the headlining or the panel.

- Remove the panel by pulling upwards slightly and unhooking it from the side panel.

Finishing work

- 11** – Remove the panel and the screws for the rear headlining
- Carefully pry off the panel at the rear edge using a plastic weatherstrip tool
 - Pull the rear edge of the panel downwards until the four clips on the top have released
 - If the car has lighting in the panel, disconnect the connector
 - Pull the panel backwards to release it.
- 12** – Carefully detach the D-post panels starting at the top edge. Then pull down until the three clips on the inside release.
- NOTE! Do not damage the panel.**
- Disconnect the connector for the D-post loudspeaker if applicable
 - Remove the panel by pulling upwards slightly and unhooking it from the side panel.
- 13** **Illustration A shows the removal of the cover for the load securing eyelets**
- Fold out the load securing eyelet
 - Insert a scribe with an angled tip into the hole in the top of the cover
 - Turn the scribe so that the angled tip engages in the reverse of the cover (1). Pull off the cover.
- Illustration B shows cars with two rows of seats**
- Illustration C shows cars with three rows of seats**
- **Applies to cars with three rows of seats:** Fold down the third row of seats
 - Remove the screws (2) for the load securing eyelets in the left-hand side panel
 - Remove the covers (3) over the front mountings for the left-hand side panel. Pry them off using a plastic weatherstrip tool or a small screwdriver
 - Remove the screws (4)
 - **Applies to cars with three rows of seats:** Remove the clip (5) at the bottom of the storage compartment in the panel
 - Pull out the upper edge of the panel a little to release the clips on the inside. Remove the panel by pulling it straight upwards.
- 14** **Connecting the positive power supply / charging function (15 I supply)**
- Install the relay in the rear electronic module (REM) terminal MA 1.
- NOTE! The relay is already installed in MA1 on cars with all wheel drive and cars with reverse warning as an accessory.**
- Install a 20A fuse in the rear electronic module (REM) terminal 15.

15 Reinstall:

- the left-hand side panel using the screws and cover if these were removed. Tighten the load securing eyelet screws. Tighten to **24 Nm (18 lbf. ft.)**
- the covers for the load securing eyelets
- the D-post panel and the connector for the D-post loudspeaker (if applicable)
- the rear roof lighting connector (if applicable)
- the rear headlining
- the C-post panel
- the protective cover and the bracket for the battery
- the folding side panels
- the storage compartment and floor hatches.

16 Checking the 7-pin connector

- 1 Parking lamps
- 2 Charging
- 3 Right indicators
- 4 Electrical brake
- 5 Ground
- 6 Left indicators
- 7 Reserve
- 8 Right indicators
- 9 Left indicators
- 10 Parking lamps
- 11 Ground.