

Section	Group	Weight (Kg/Pounds)	Year	Month
8	89		2004	01

Fixed tow hitch EU

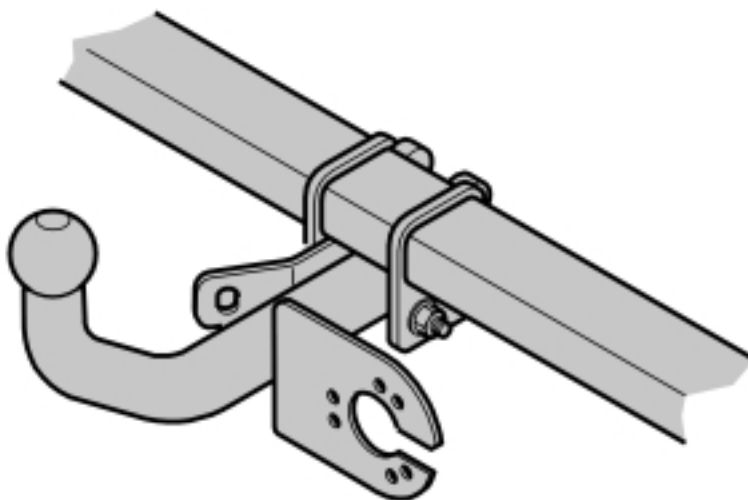

M8901547



A0000162



A0000163



Nm
lbf.ft

A0000161



A0000172



A0000165

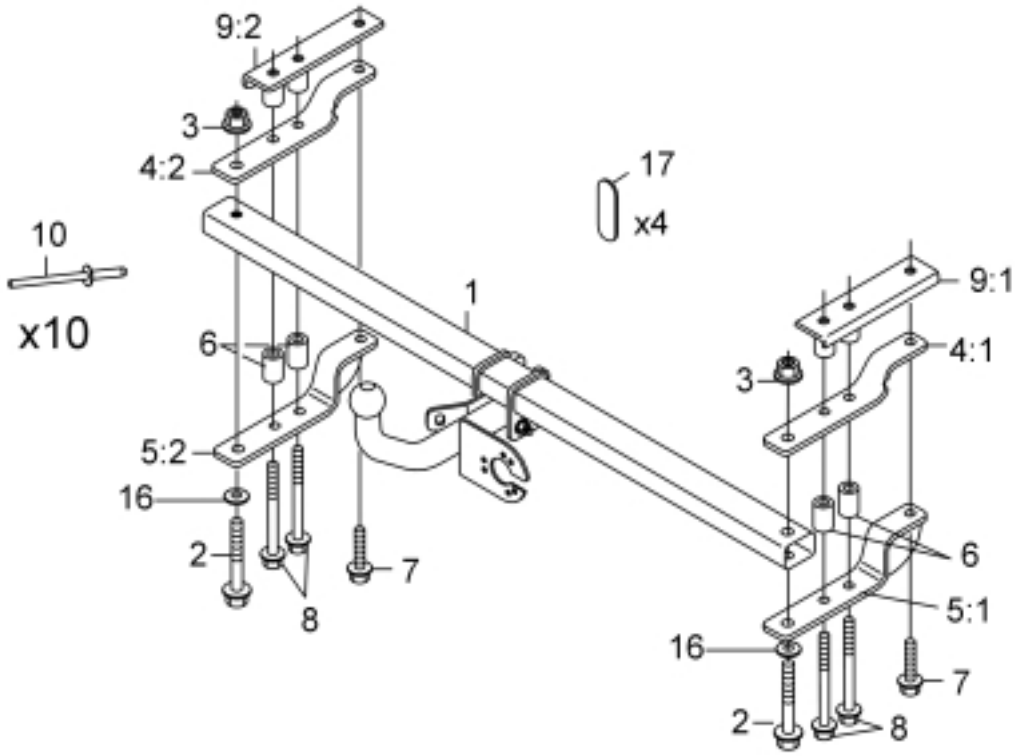

M8901502

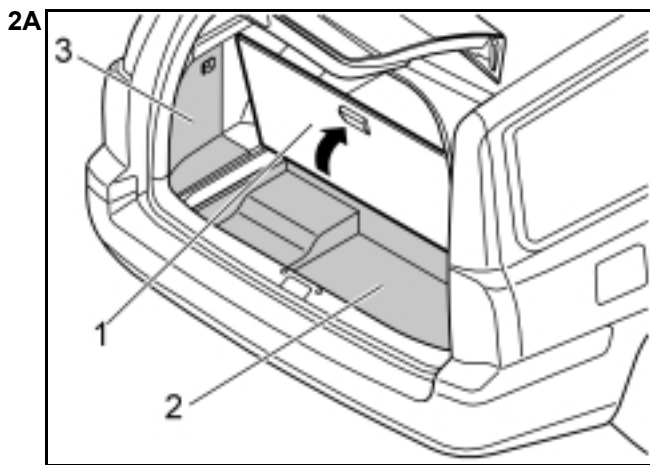

M8301410

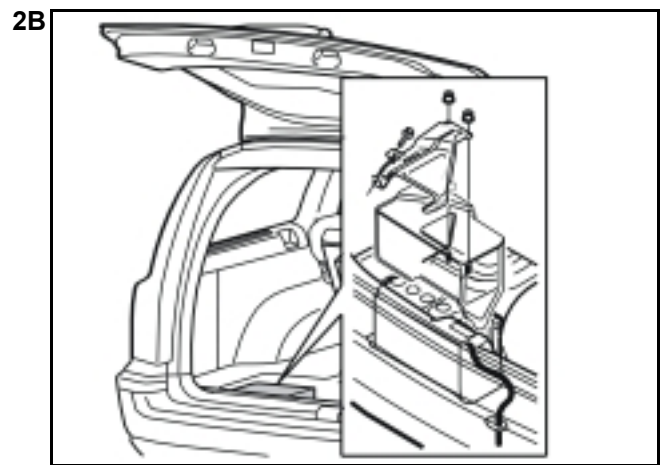

M3100145

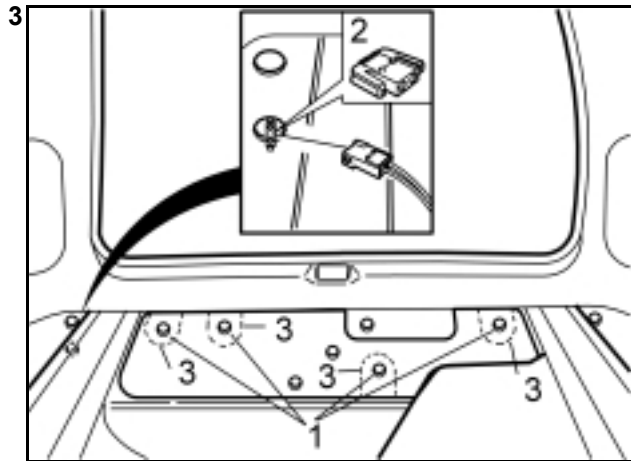

M8101064

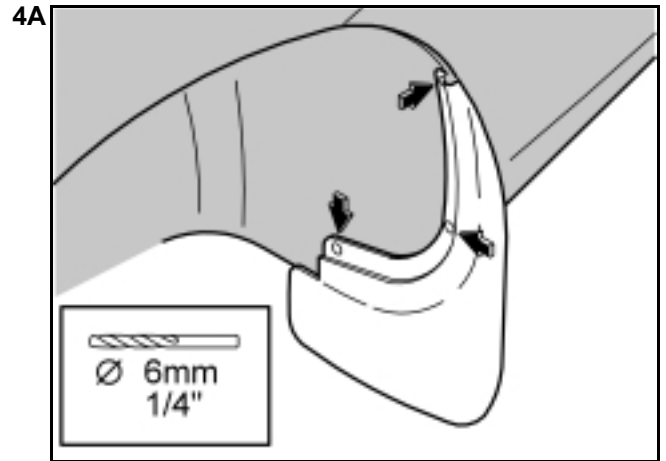

M8600488

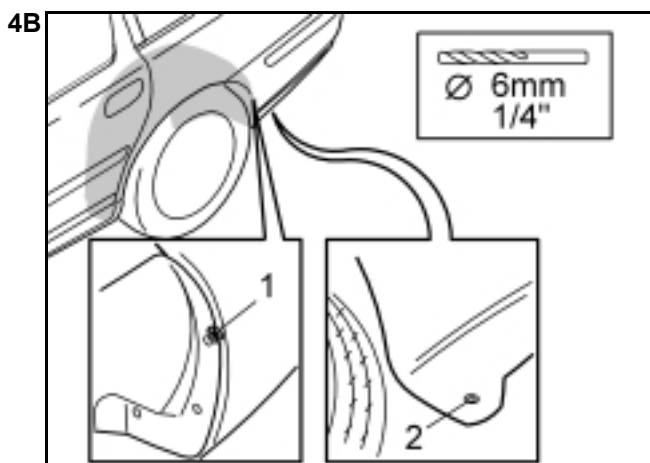

M8600489

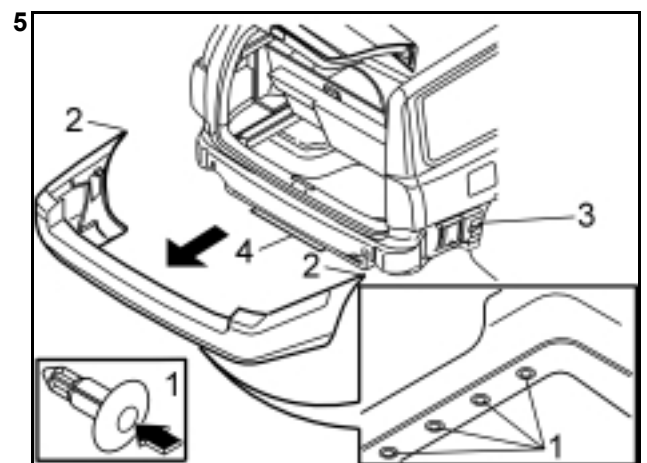

M8600494

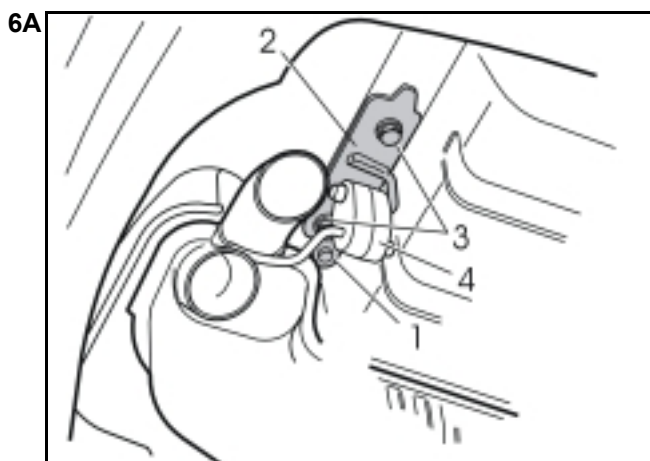

D2500722

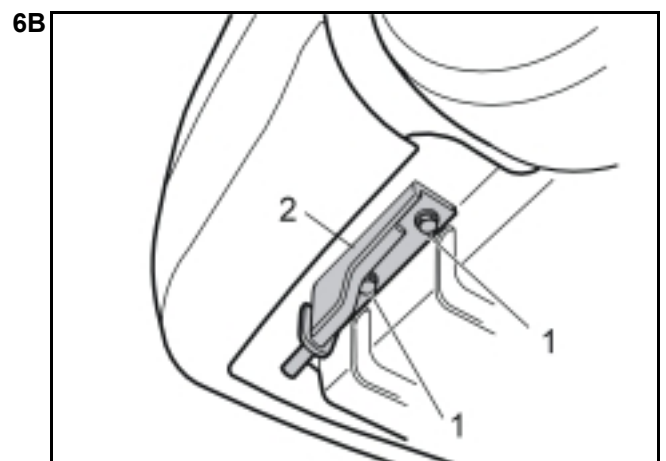

D8600247

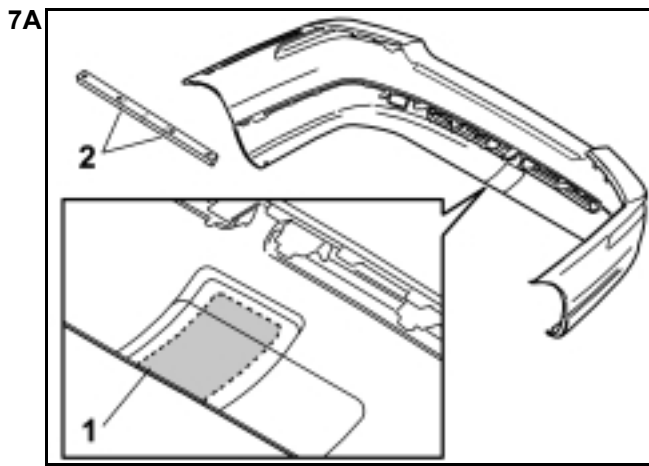

M8903768

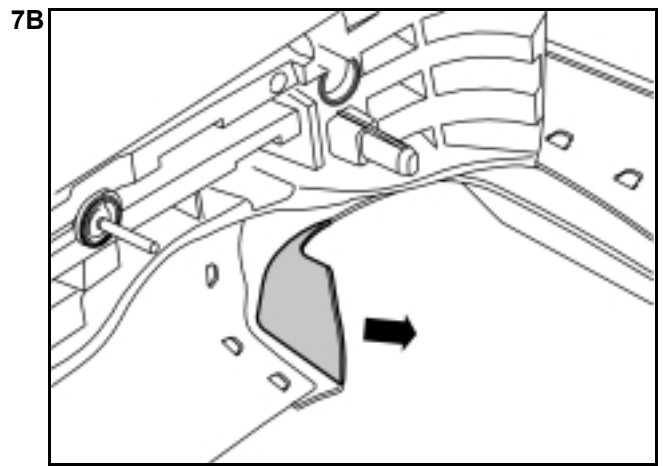

M8903417

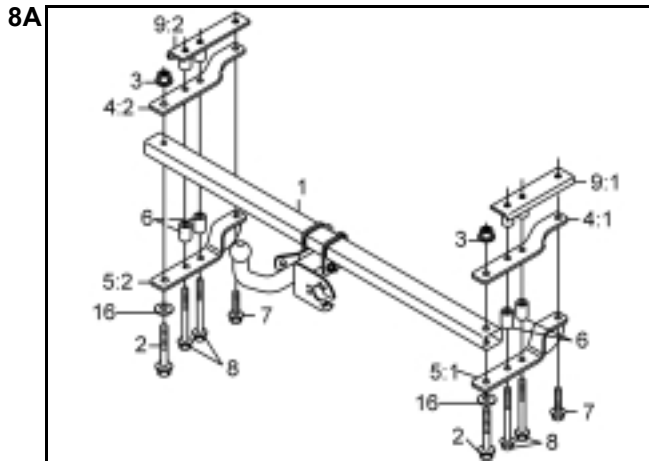

M8901542

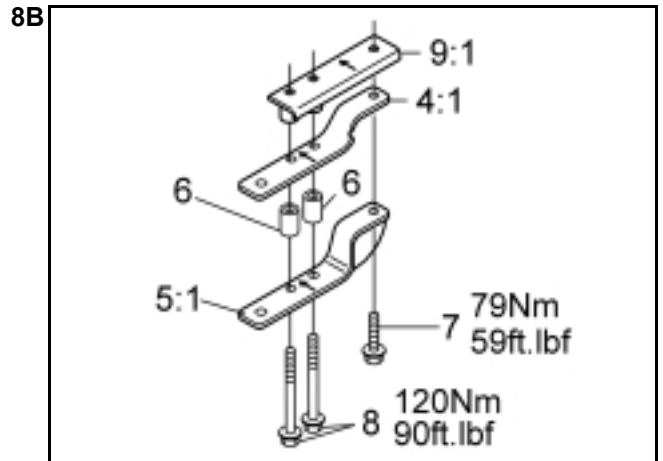

M8901566

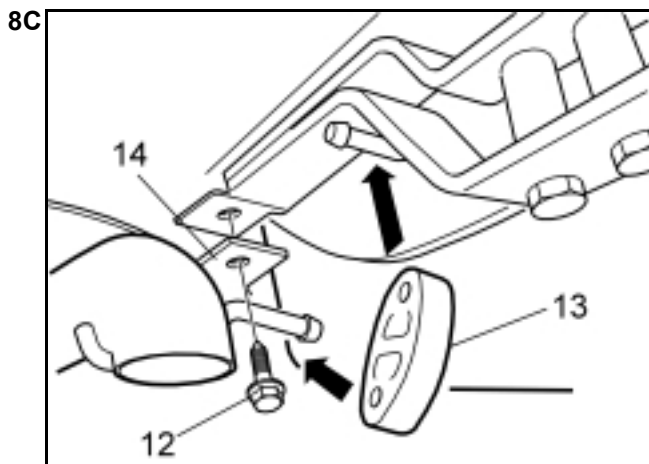

M8901484

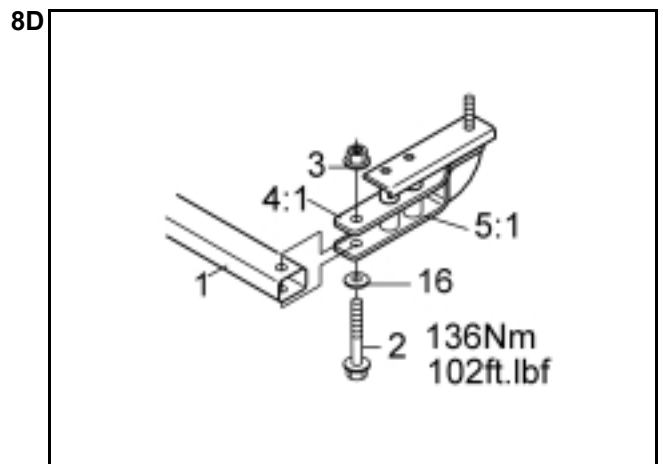

M8901567

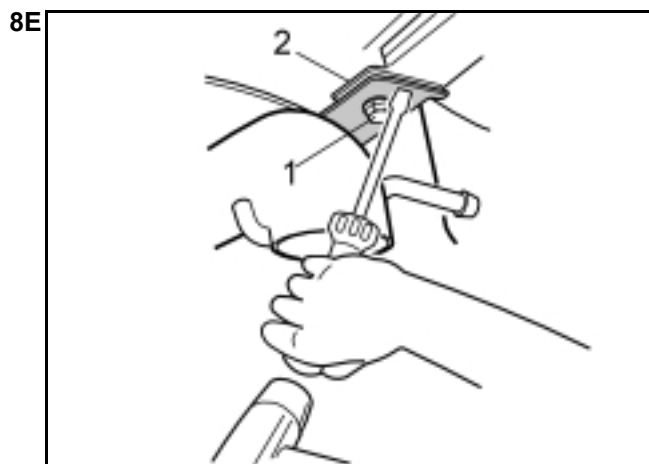

M8901646

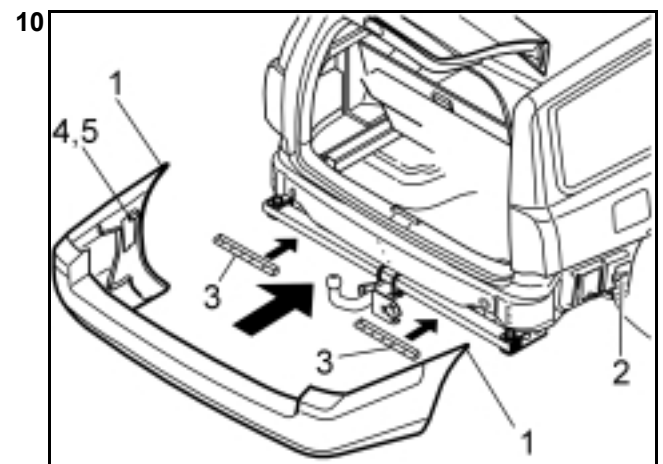

M8600435

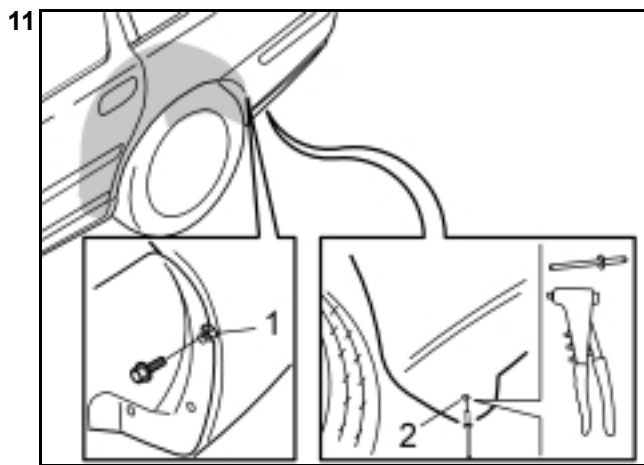

M8600491

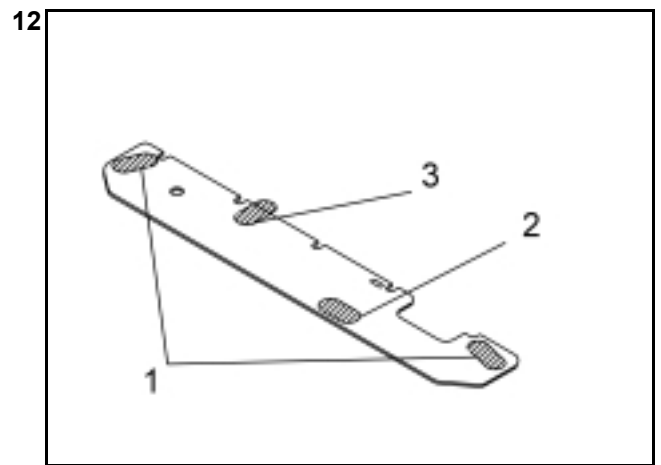

M8101962

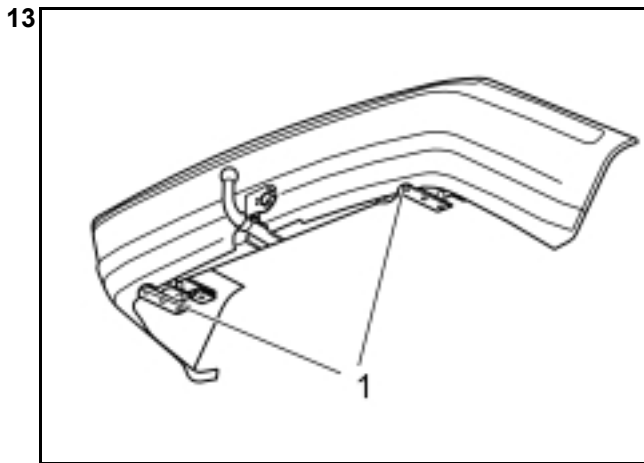

M8600436

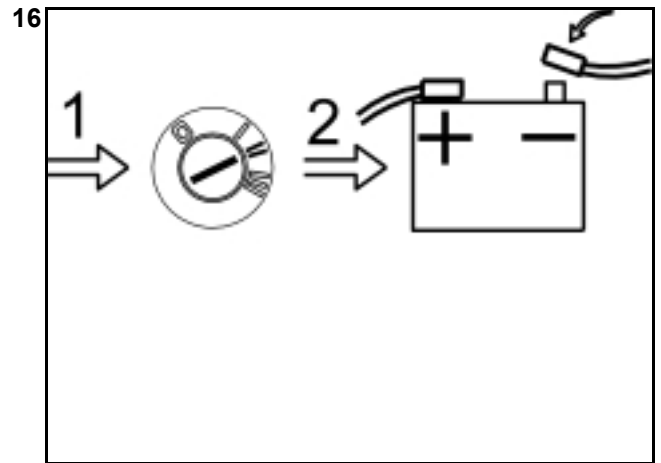

A8800137

English

INTRODUCTION

- **NOTE! Read through the entire text before carrying out any work.**
- The front page gives the date of this edition and the edition it replaces
- The second page shows the tools needed for the installation and the contents of the installation kit
- The illustrations display the procedure in order of operation. The order of operation is repeated in the text section
- Cut out the text page in order to follow the illustrations and text at the same time.

Fixed tow hitch

NOTE!

Kit contents:

- 1 Cross member (x1)
- 2 Screw M14 x 80 (x2)
- 3 Nut M14 (x2)
- 4 Upper bracket (x2)
- 5 Lower bracket (x2)
- 6 Sleeve (x4)
- 7 Screw M12x50 (x2)
- 8 Screw M12x130 (x4)
- 9 Reinforcement panel with sleeves (x2)
- 10 Blind rivet (x10)
- 11 Washer (x2)
- 12 Rubber tabs (x4).

NOTE! Type approval of the tow hitch is in the table on page 2.

NOTE! A new lining mat is required for cars manufactured up to week 13, 2000. The lining mats are ordered separately for these cars, P/N 8625515.

NOTE! It is recommended that operations 6 and 12 are carried out by two people.

- 1
 - Turn the ignition key to position 0
 - Remove the ignition key.

NOTE! Wait at least 5 minutes before disconnecting the connectors or removing other electrical equipment.

2 Illustration 2A

- Lift and remove the floor hatch (1)
- Lift and remove the storage cover (2)
- Remove the side panel (3) on the left-hand side.

Illustration 2B

- Remove the cover from the battery. Remove the two nuts from the front edge of the holder. Slacken off the screws at the rear of the holder a few turns. Remove the holder
- Remove the battery cover
- Disconnect the battery negative lead
- Move or remove the battery to facilitate access.

3 Applies only if the car has a lining mat with 4 perforations

- Remove the perforated sections (3) from the lining mat.

Applies only if the car has a lining mat with 1 perforation

- Remove the lining mat.

Applies to all cars

- Remove the nuts (1) in the rear crossmember. This allows the bumper to be removed
- Separate the connector (2) for the antenna.

4 – Raise the car.

Illustration 4A only applies to cars with mudguards

- Remove the rear wheels
- Carefully drill out the rivets holding the mudguard on both sides. Use a **6 mm (13/32")** diameter drill bit
- Remove the mudguards.

Illustration 4B applies to all cars

- Carefully drill out the rivet (2) at the bottom of the bumper on both sides. Use a **6 mm (13/32")** diameter drill bit
- Remove the screw (1) holding the liner for the bumper cover on both sides.

Do not damage any of the plastic components.

5 **Only applies if the car has clips**

- Remove the clips (1) at the bottom of the bumper cover. Press in the centre of the clip until it clicks. Remove the clips. The clips will be reused.
- Pull the bumper backwards slightly. Bend out the sides (2) so that they detach from the mounting (3). Then pull the bumper backwards until it detaches completely
- Place the bumper on an underlay which will not damage the paint.

Only applies if the car is equipped with mouldings

- Carefully remove the moulding (4) from the expander clips.

6 **Illustration 6A**

- Remove the rivet (1) on the bracket (2) for the silencer. Use cutting nippers
- Remove the screws (3) on the bracket
- Remove the rubber mountings (4). Remove the bracket.

The bracket will not be used again.

Illustration 6B

- Remove the screws (1). Remove the bracket (2).

The bracket will not be used again.

7 **Illustration A**

- Install masking tape on the outside of the bumper to avoid damage from the foot of the saw
- Leave the masking tape in place throughout the installation procedure
- Saw along the inside of the flange (1), on the underside of the bumper so that the flange stays in place in the bumper
- After cutting, smooth off the edges using a file.

Only applies if the car is equipped with mouldings

- Also saw out the moulding as marked (2).

Illustration B only applies to V70-R up to and including model year 2004

- Install masking tape on the outside of the exhaust pipe cover to avoid damage from the saw. Leave the masking tape in place throughout the installation procedure
- Saw along the marked projection. Remove the cut out surface
- After cutting, smooth off the edges using a file.

- 8** Illustration 8A shows how the tow hitch and its components are assembled and installed on the car body.

Illustration 8B shows how the brackets are installed onto the body.

Illustration 8C shows the installation of the rubber mounting for the exhaust system.

Illustration 8D shows how the member is installed into the brackets.

Illustration 8E shows how to bend the heat deflector plate.

- Clean any underseal and dirt from the surfaces between the tow hitch and the bodywork.

Illustration 8B is carried out on both sides. The right side is displayed

- Install the screws (7, 8) from the underside of the brackets (4:1, 5:1, 9:1), including the sleeves (6). Hand tighten. The arrows on the brackets (4:1, 5:1, 9:1) must point towards the centre of the car.

Illustration 8C

- Install the heat deflector plate (14) with the screw (12). See point 8E.

Illustration 8E

- Screw the heat deflector plate into place on the member (2) using the screw (1). Hand tighten
- Bend the heat deflector plate. Use a screwdriver
- Screw in the screw completely.

Illustration 8C

- Reinstall the rubber mounting (13) for the silencer. Use soap to facilitate installation.

Illustration 8D

- Insert the member (1) between the brackets (4, 5). Centre the member around the holes
- Install the screws (2) and the washers (16) from the underside of the bracket (5). Install the nuts (3) from above the bracket. Do not tighten.

Illustration 8A

- Check that the distance between the member (1) and the spare wheel well is 10 mm. Centre the tow hitch to the car.

Illustration 8B applies to both sides. The right-hand side is shown (the holes are then on the left-hand side)

- Tighten the screws (7). Tighten to **79 Nm (58 lbf. ft.)**
- Tighten the screws (8). Tighten to **120 Nm (88 lbf. ft.)**.

Illustration 8D

- Tighten the screws (2) and nut (3). Tighten to **136 Nm (100 lbf.ft.)**
- Wait at least five minutes, so that the joint has time to set. Then tighten the screws (8) on both sides, a quarter turn (angle tighten 90°).

NOTE! Torque tightened screws that have been removed must not be reused.

- 9** – Apply underseal.

Applies to Sweden only

- Carry out this operation only after the State road worthiness inspection.

10 **Only applies if the car is equipped with mouldings**

- Reinstall the mouldings (3) on the expander clips. Press the mouldings into place.

Applies to all models

- Reinstall the guide lugs (3) and the clips (4) if they have been removed
- Reinstall the bumper by pressing it forwards. Ensure that the four screws that are protruding from the bumper align with the holes in the car
- Before the bumper is completely installed slide in the top edge (1) in its grooves. Then slide in the bumper fully
- Check that the guide lug (4) and the clip (5) are centred with the hole in the wheel arch lining.

- 11** – Tighten the screw (1) on both sides

- Rivet (2) the bumper into place as illustrated.

Only applies if the car is equipped with clips and mouldings

- Reinstall the clips at the bottom edge of the bumper. This is to secure the bumper at the mouldings, see point 5. Ensure that the locks in the clips are in the normal position.

Applies to all models

- Reinstall the nuts. Tighten the nuts. Tighten to **18 Nm (13 lbf.ft.)**. See point 3
- Connect the antenna connector.

Applies to cars with mudguards

- Rivet the mudguard into place. See point 4A
- Reinstall the wheels. Tighten the screws crosswise. Tighten to **110 Nm (81 lbf.ft.)**.

12 Applies only if the car has a lining mat with 4 perforations. See point 3

Install the rubber tabs (from the kit) over the four installed screws as follows:

- Align the rubber tabs (1) edge to edge with the lining mat
- Press the rubber tab (2) together slightly to align in the cut out
- Align the rubber tab (3) so that the lower edge is edge to edge with the lining mat. Cut off the section protruding from the lining mat - do not cut too much off.

Applies only if the car has a lining mat with 1 perforation. See point 3

- Install a new lining mat.

- 13** – If necessary, cut away the area (1) around the screw heads so that the screws are accessible.
- 14** – Connect the cable harness connector for the tow hitch according to point 1 in the Installation Instructions for the appropriate cable harness.
- 15** – Install the cable harness for the tow hitch according to point 2 and onwards in the Installation Instructions for the appropriate cable harness.
- 16** – Turn the ignition key to position (II)
– Reconnect the battery negative lead. Reinstall the covers
– Reinstall the right side panel. Install the clips
– Reinstall the storage cover and the floor hatch
– Reinstall the panel for the rear crossmember
– Fold back the carpet.
- 17** – Install the trailer connector according to the Installation Instructions for the appropriate cable harness.
- 18** – Remove the masking tape from the bumper.