

MAINTENANCE INFORMATION

1995 Volvo 850

1993-96 MAINTENANCE
Volvo Maintenance Information

1993-96 850 Sedan
1994-96 850 Turbo Sedan
1995-96 850 T-5R Turbo Sedan
1994-96 850 Wagon
1994-96 850 Sportswagon
1995-96 850 T-5R Turbo Sportswagon

* PLEASE READ THIS FIRST *

NOTE: For scheduled maintenance intervals and the related fluid capacities, fluid specifications and labor times for major service intervals, see SCHEDULED SERVICES article below:

- * SCHEDULED SERVICES - NON TURBO
- * SCHEDULED SERVICES - TURBO (1994-96)

Warranty information and specifications for fluid capacities, lubrication specifications, wheel and tire size, and battery type are covered in this article.

NEW MODEL HIGHLIGHTS

NOTE: For more information regarding 1995 Model changes refer to the GROUP 00, NO. 809 1995 850 NEW CAR FEATURES article in the TSB section.

MODEL IDENTIFICATION

VIN LOCATION

The Vehicle Identification Number (VIN) is located on the left side of the dash panel at the base of the windshield. The VIN chart explains the code characters.

VIN CODE ID EXPLANATION

Numbers preceding the explanations in the legend below refer to the sequence of characters as listed on VIN identification label. See VIN example below.

(VIN)	Y	V	1	L	S	5	5	1	X	P	1	0	0	0	0	0	1
	1	2	3	4	5	6	7	8	9	10	11	12	13	14	15	16	17

1 - Manufacturing Country
Y * Sweden Or Belgium

2 - Manufacturer
V * Volvo

3 - Vehicle Type
1 * Passenger Vehicle

4 - Vehicle Series

- L * 850 Sedan
- 5 - Body Style & Restraint System
 - S * 850 4-Door Sedan W/ Driver & Passenger Airbags
 - S * 850 4-Door W/ Dual Airbags & Pretentioners
 - W * 850 5-Door Wagon W/ Driver & Passenger Airbags
- 6-7 - Engine Type
 - 55 * B5254S 2.4L 5-Cylinder
 - 57 * B5234T 2.3L Turbo 5-Cylinder
 - 58 * B5234T5 2.3L Turbo 5-Cylinder
- 8 - Emission Control System
 - 0 * Three-way Converter, Heated Oxygen Sensor, W/O EGR
 - 1 * Three-way Converter, Heated Oxygen Sensor, W/EGR
 - 2 * Three-way Converter, Heated Oxygen Sensor, W/EGR, Airpump
- 9 - VIN Check Digit
 - * Computer Generated
- 10 - Vehicle Model Year
 - P * 1993
 - R * 1994
 - S * 1995
 - T * 1996
- 11 - Assembly Plant
 - 0 * Kalmar, Sweden
 - 1 * Torslanda, Sweden
 - 2 * Ghent, Belgium
 - 3 * Halifax, Nova Scotia, Canada
 - A * Uddevalla, Sweden
- 12-17 - Serial Number
 - * Sequential Production Number

MAINTENANCE SERVICE INFORMATION

SEVERE & NORMAL SERVICE DEFINITIONS

NOTE: Use the Severe Service schedule if the vehicle to be serviced is operated under ANY (one or more) of these conditions:

Service is recommended at mileage intervals based on vehicle operation. Service schedules are based on the following primary operating conditions:

Normal Service

- * Driven More Than 10 Miles Daily
- * No Operating Conditions From Severe Service Schedule

Severe Service (Unique Driving Conditions)

- * Extended Idling Or Low Speed Operation
- * Frequent Short Trips Of Less Than 7 Miles
- * Extended Operation In Dusty Or Sandy Conditions
- * Trailer Towing Operations
- * Driving In Mountainous Conditions

CAMSHAFT TIMING BELT

CAUTION: Failure to replace a faulty camshaft timing belt may result in serious engine damage.

The condition of camshaft drive belts should always be checked on vehicles which have more than 50,000 miles. Although some manufacturers do not recommend belt replacement at a specified mileage, others require it at 60,000-100,000 miles. A camshaft drive belt failure may cause extensive damage to internal engine components on most engines, although some designs do not allow piston-to-valve contact. These designs are often called "Free Wheeling".

Many manufacturers changed their maintenance and warranty schedules in the mid-1980's to reflect timing belt inspection and/or replacement at 50,000-60,000 miles. Most service interval schedules in this manual reflect these changes.

Belts or components should be inspected and replaced if any of the following conditions exist:

- * Cracks Or Tears In Belt Surface
- * Missing, Damaged, Cracked Or Rounded Teeth
- * Oil Contamination
- * Damaged Or Faulty Tensioners
- * Incorrect Tension Adjustment

Volvo recommends replacement of the camshaft timing belt at the following intervals:

CAMSHAFT TIMING BELT REPLACEMENT INTERVAL TABLE

Application	Interval (Miles)
1993	50,000
1994-96	70,000

SERVICE POINT LOCATIONS

**Engine compartment 850
(engine B 5254 S / B 5252 S)**

- 1 Expansion tank, coolant
- 2 Engine designation plate
- 3 Oil filler cap, engine
- 4 Clutch/brake system fluid reservoir
- 5 Fuse box
- 6 Washer fluid reservoir
- 7 Power steering fluid reservoir
- 8 Dipstick - engine oil
- 9 Dipstick - automatic transmission
- 10 Air cleaner
- 11 Battery
- 12 Data plate

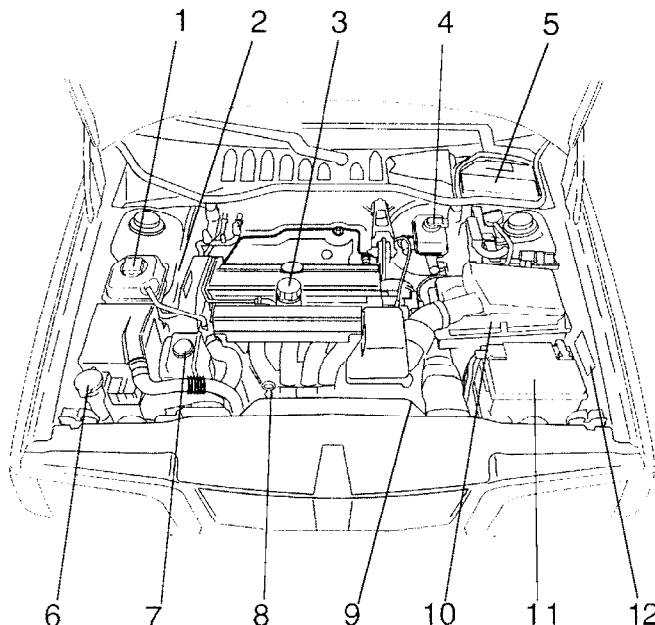

50H11921

Fig. 1: Service Point Locations (Non-Turbo)
Courtesy of Volvo Cars of North America.

**Engine compartment 850 Turbo
(engine B 5234 T)**

- 1 Expansion tank, coolant
- 2 Engine designation plate
- 3 Oil filler cap, engine
- 4 Clutch/brake system fluid reservoir
- 5 Fuse box
- 6 Washer fluid reservoir
- 7 Power steering fluid reservoir
- 8 Dipstick - engine oil
- 9 Dipstick - automatic transmission
- 10 Air cleaner
- 11 Battery
- 12 Data plate

50111922

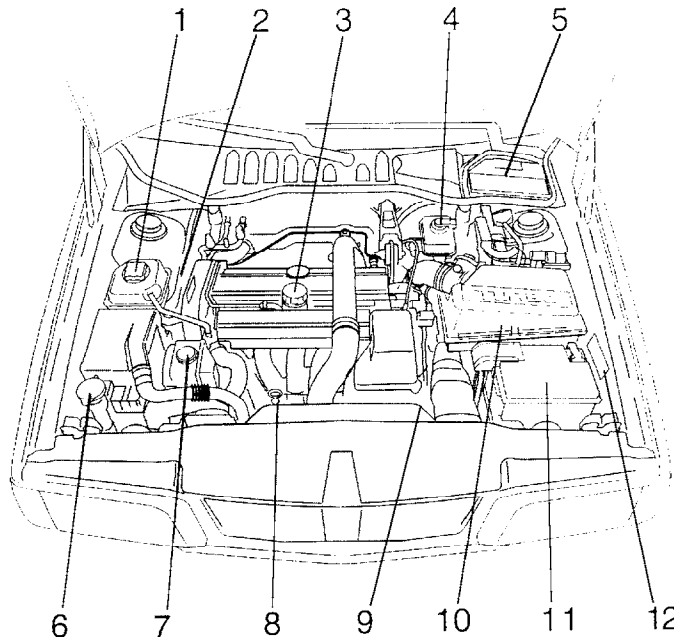

Fig. 2: Service Point Locations (Turbo)
Courtesy of Volvo Cars of North America.

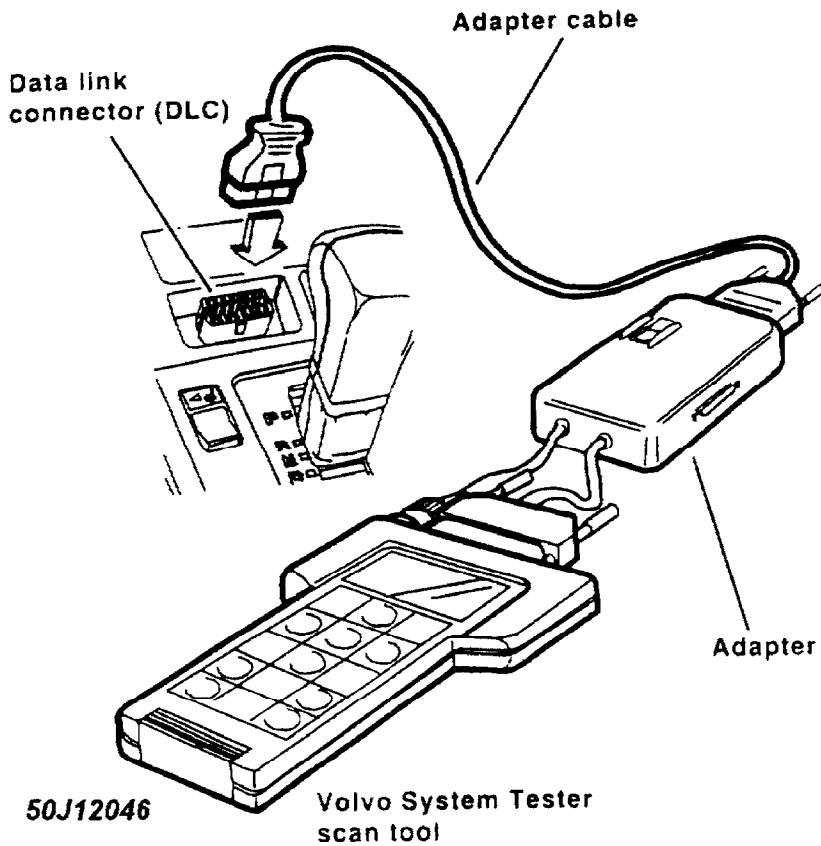
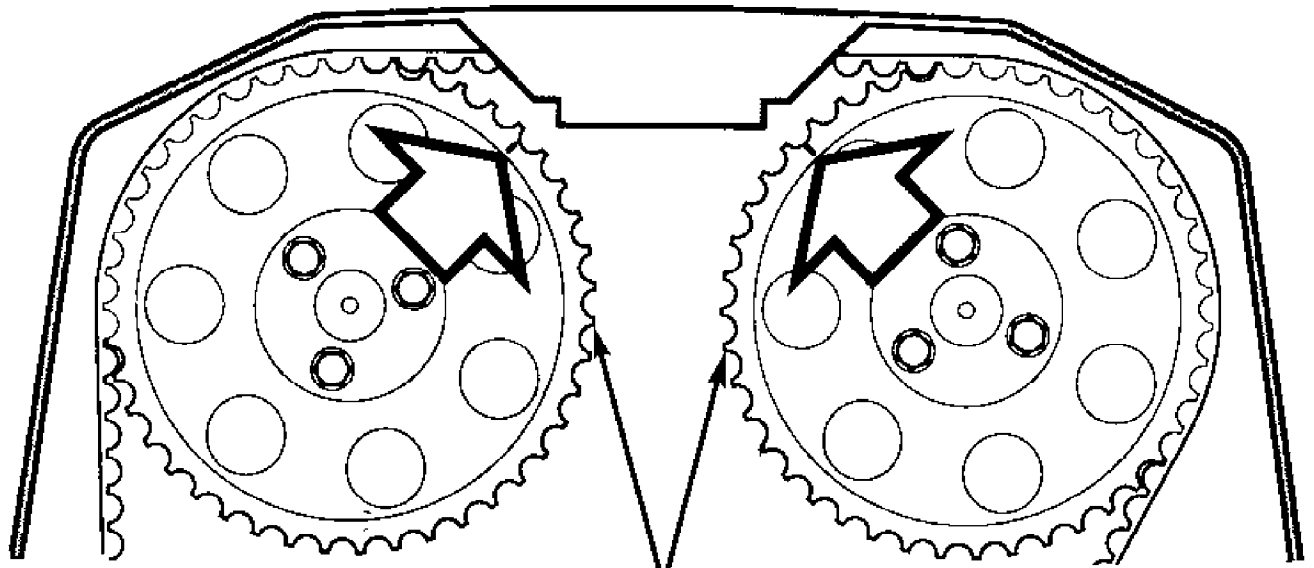
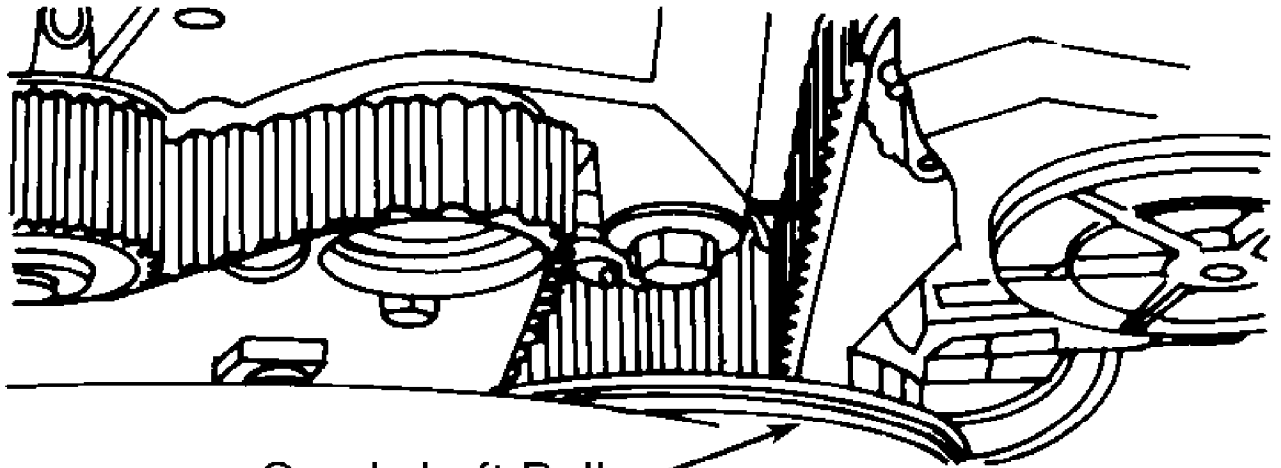

Fig. 3: OBD II Diagnostic Link Connector Location (1996)
Courtesy of Volvo Cars of North America.

ALIGNING CAMSHAFT TIMING MARKS



Camshaft Pulley



Crankshaft Pulley

93E01228

Fig. 4: Aligning Camshaft & Crankshaft Timing Marks
Courtesy of Volvo Cars of North America.

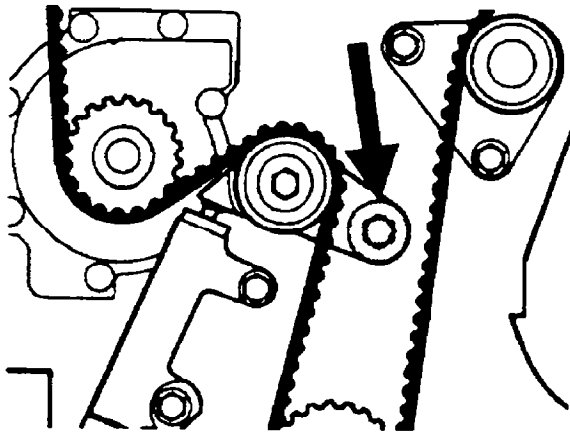

50H11905

Lubricating bushing

Remove:

- lever mounting screw
- tensioner pulley
- sleeve behind screw.

Lubricate surfaces of bushing, screw and sleeve with grease P/N 1161246-2 (50 grams) or 1161247-0 (500 grams).

Reinstall:

- sleeve
- tensioner pulley
- lever mounting screw.

Torque screw to 29 ± 5 ft lb = 39 ± 5 Nm.

Torques:

Pulley lever: **30 ft lb = 40 Nm**

Idler pulley: **18 ft lb = 25 Nm**

Fig. 5: Lubricating Tensioner Pulley Bushing (Pivot Bearing)
Courtesy of Volvo Cars of North America.

CAUTION: Lubrication of the Tensioner Pulley Bushing is REQUIRED on 1993 Models, it is recommended that the bushing be checked for free play and lubrication on 1994-95 models.

NOTE: For more information regarding camshaft timing belt service refer to the 2.3L 5-CYL TURBO article in the ENGINE MECHANICAL section.

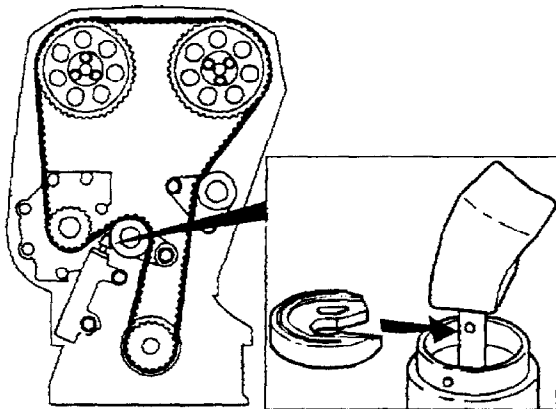

Washer installation

Place **new** washer on piston stem of belt tensioner.

Check that washer centers on piston stem and tensioner case.

NOTE!

Make sure that correct side of washer is turned up. The countersunk side should face up. See illustration.

50I11906

Fig. 6: Installing Washer on Timing Belt Tensioner
Courtesy of Volvo Cars of North America.

MODEL 850 TIMING BELT REPLACEMENT TABLE

Model Year	Part Number	50K	60K	70K	80K	90K	100K
1993*	271952-4	X					X
1994	271834-4			E			

* = Late M/Y 93 850's (from engine no. 131035) should have M/Y 94 timing belt (p/n 271834-4). See Parts Bulletin 21-13 and Tech DCS 21-02.
E = Recommended timing belt replacement
X = Required timing belt replacement

NOTE: On 1993 850's, lubricate timing belt tensioner pivot bearing during timing belt replacement.

LUBRICATING AUXILIARY DRIVE BELT TENSIONER

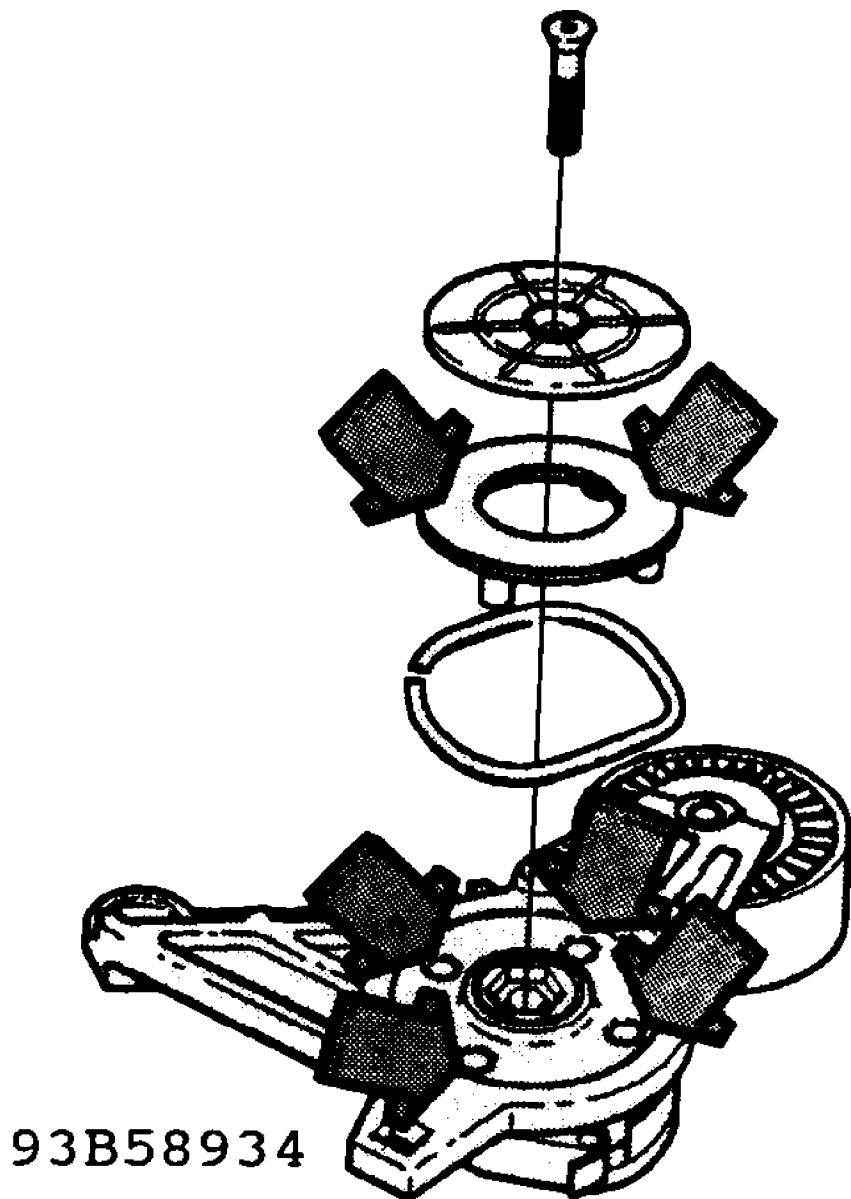

Fig. 7: Auxiliary Drive Belt Tensioner Lubrication Points
Courtesy of Volvo Cars of North America.

NOTE: The automatic tensioner for the auxiliary drive belt must be greased every 30,000 miles (45,000 km) or if an abnormal

noise is heard from the tensioner.

NOTE: The auxiliary drive belt and automatic tensioner must be removed from engine in order to properly lubricate.

FLAME TRAP MAINTENANCE - PCV SYSTEM

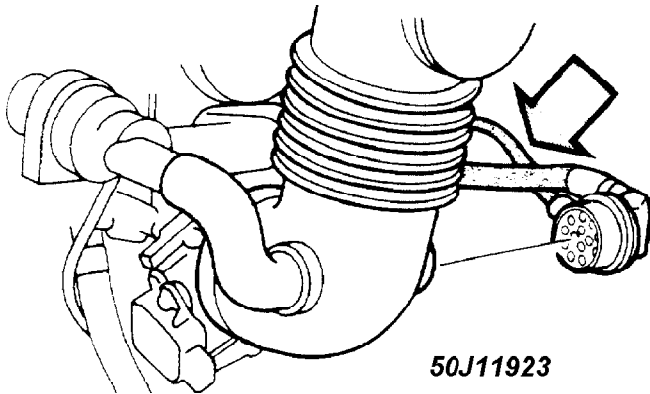

Check flame trap

Remove flame trap by rotating it approx. $0.59^{\circ} = 15 \text{ mm}$ left (bayonet catch).

Blow clean hoses towards crankcase ventilation.

Important

Do not undo hoses from flame trap outer casing. Hose location may affect function of throttle control.

Fig. 8: Flame Trap Location
Courtesy of Volvo Cars of North America.

CHANGING CONTROL MODULE BOX FILTER (1993)

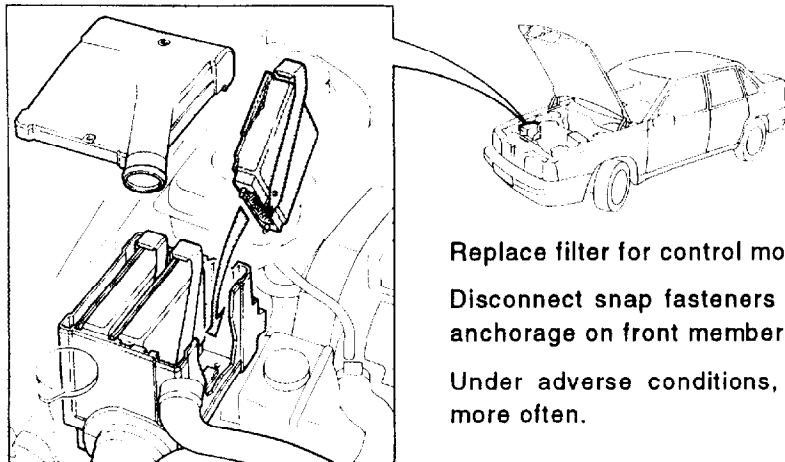

Replace filter for control module box.

Disconnect snap fasteners and remove air duct from anchorage on front member.

Under adverse conditions, filter should be replaced more often.

Fig. 9: Control Module Box Filter (1993)
Courtesy of Volvo Cars of North America.

BODY LUBRICATION POINTS

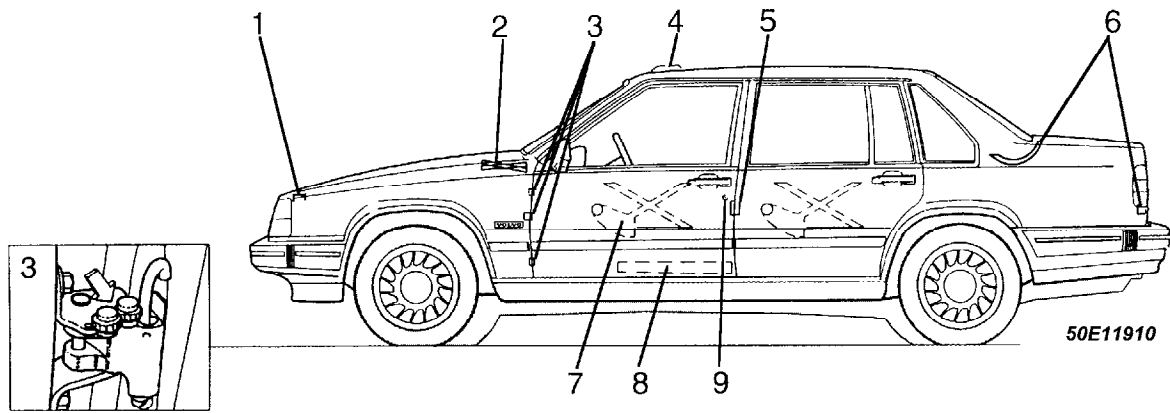

Door Stop

No. Lubricating hint	Lubricant	No. Lubricating hint	Lubricant
1 Hood lock and latch	Oil	7 Window regulator locking device (on inside of door)	Oil, grease low temperature grease
2 Hood hinges	Oil	8 Front seat slide rail and latch	Oil
3 Door stop and hinges	Oil	9 Door lock keyhole	Low temperature grease or Volvo Teflon lock oil
4 Sun roof wind deflector	Oil		
5 Door lock catch plate	Oil		
6 Trunk lid lock keyhole and hinges	Low temperature grease		

Fig. 10: Body Lubrication Points (Typical)
Courtesy of Volvo Cars of North America.

VEHICLE LIFT POINTS

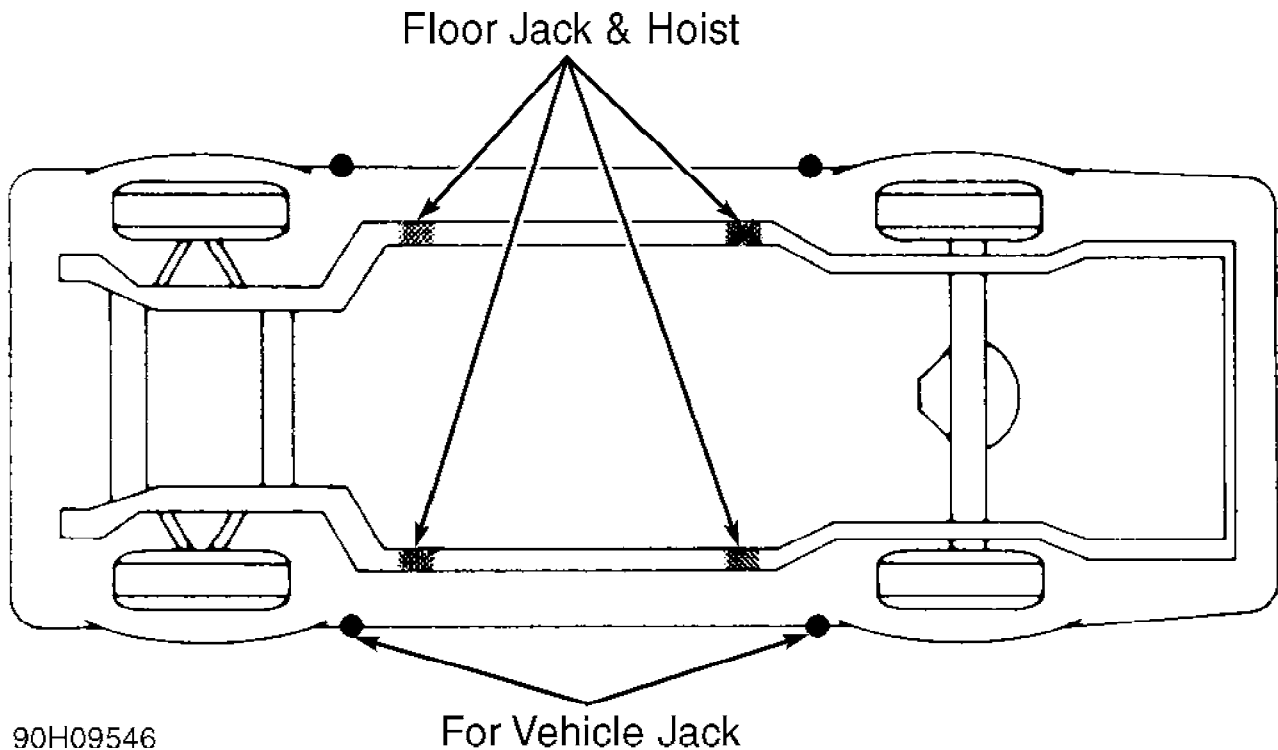

90H09546

Fig. 11: Vehicle Lift Points (Typical)
Courtesy of Volvo Cars of North America.

CAUTION: Use extreme caution when putting a T-5R model, or any model with a front spoiler and lowered suspension onto a lift.

NOTE: For more information regarding lifting and hoisting refer to the JACKING & HOISTING article in the WHEEL ALIGNMENT section.

INFORMATION LABEL LOCATIONS

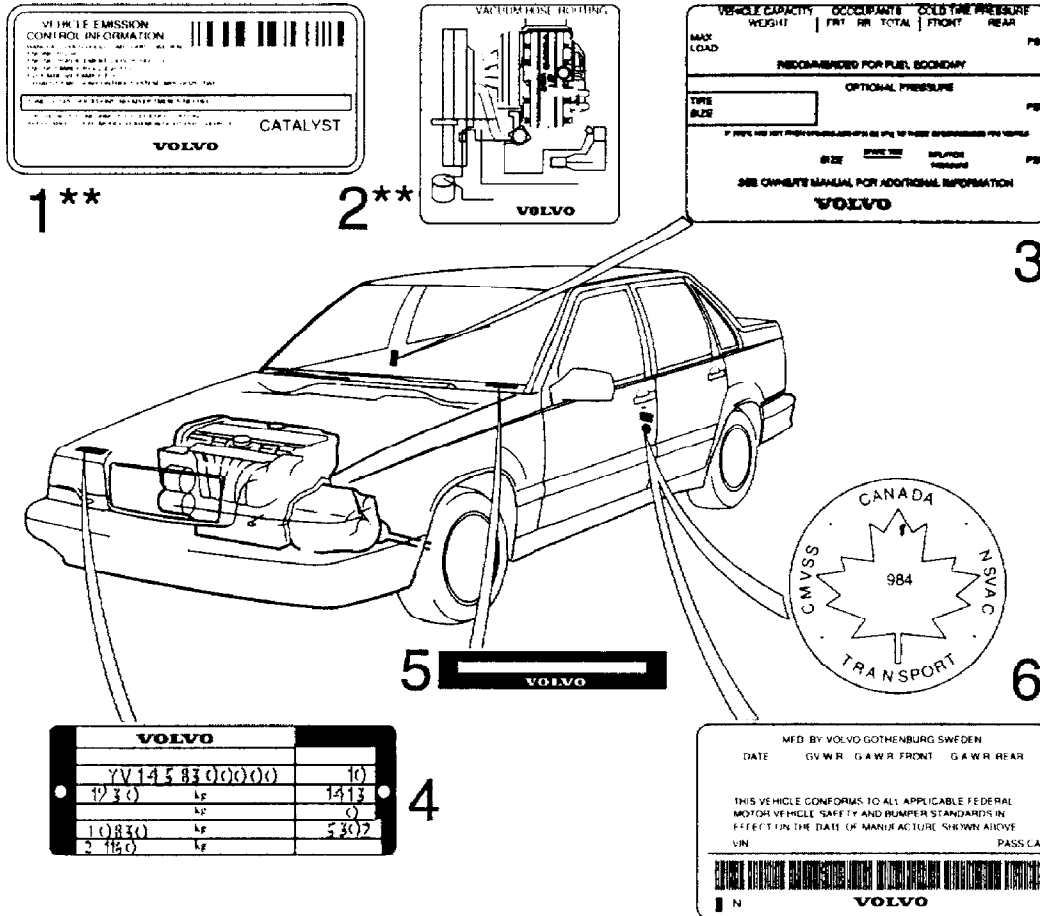

- 1 Vehicle Emission Control Information
- 2 Vacuum hose routing
- 3 Loads and Tire Pressures
- 4 Model plate
- 5 Vehicle Identification Number (VIN) *
- 6 Federal Motor Vehicle Safety Standards (FMVSS) specifications (USA) and Ministry of Transport (CMVSS) standards (Canada)

* The Vehicle Identification Number (VIN) should always be quoted in all correspondence concerning your vehicle with the dealer and when ordering parts.
 ** These decals are located on the underside of the hood.

50C11926

All specifications are subject to change without notice.

Fig. 12: Information Label Locations
 Courtesy of Volvo Cars of North America.

SERVICE LABOR TIMES

SERVICE LABOR TIMES TABLE (HOURS)

Application (1)	30,000 Mile Service	60,000 Mile Service
2.5L 5-Cylinder		
Automatic Transmission	3.8	4.6
Manual Transmission	3.8	4.6
2.5L 5-Cylinder Turbo		
Automatic Transmission	N/A	N/A
Manual Transmission	N/A	N/A

(1) - To replace camshaft timing belt, add 2.0 hrs.

LUBRICATION SPECIFICATIONS

CAUTION: DO NOT use SAE 15W-40 oil in extremely low ambient temperatures.

LUBRICATION SPECIFICATIONS TABLE

Application	Fluid Specifications
Coolant	50/50 Mix Ethylene Glycol and Distilled Water
Brake Fluid	DOT 4 Or DOT 4+ Brake Fluid
Engine Oil	
Ambient Temperature	
Less Than 68°F (20°C)	SAE 5W-30 API SH/CD
-4°F To 100°F (-20° To 38°C)	SAE 10W-30 API SH/CD
Greater Than 14°F (-10°C)	SAE 15W-40 API SH/CD
Power Steering Fluid (1)	Dexron-IIIE or Mercon ATF
Automatic Transaxle (AW50-42)	Dexron-IIIE or Mercon
Manual Transmission (2)	Volvo Synthetic (P/N 1161423) Or Type F/G ATF
Wheel Bearings	NLGI Grade 2 Category GC-LB
Steering Linkage (3)(4)	NLGI Grade 2 Category GC-LB
Ball Joints (3)(5)	NLGI Grade 2 Category GC-LB
Weatherstrip	Dielectric Silicone Grease

(1) - At temperatures below -4°F (-20°C) Volvo oil (P/N1161001-1) can be used.

(2) - DO NOT use Dexron fluid in manual transmissions.

(3) - Use low pressure grease gun to prevent seal damage.

(4) - Fill until lubricant squeezes out from the base of seals.

(5) - Fill ball joint until seal starts to swell.

FLUID CAPACITIES

FLUID CAPACITIES TABLE

Application	Quantity (1)
A/C R-134a Refrigerant	26 Ozs.
Brake System	0.5 Qts. (0.6L)
Cooling System	
Non-Turbo	7.6 Qts. (7.2L)
Turbo	7.4 Qts. (7.0L)
Engine Oil (2)	

850 (Non-Turbo)	
1993-94	5.6 Qts. (5.3L)
1995 (M/T)	5.6 Qts. (5.3L)
1995 (A/T)	6.1 Qts. (5.8L)
Turbo (3)	
Without Oil Cooler	5.6 Qts. (5.3L)
With Oil Cooler	6.5 Qts. (6.2L)
Fuel Tank	19.3 Gals. (73L)
Power Steering	0.7 Qts. (0.8L)
Automatic Transmission (AW50-42)	
Fluid Change	3.3 Qts. (3.0L)
Overhaul	8.0 Qts. (7.6L)
Manual Transmission	
1993-94 (M56L)	2.5 Qts. (2.1L)
1995-96 (M56H)	2.2 Qts. (2.1L)

- (1) - Capacities are recommended or calculated levels. Always use dipstick (if available) to measure level.
(2) - Includes Filter Change
(3) - Oil Cooler capacity is .95 Qts. (0.9L).

WHEEL & TIRE SPECIFICATIONS

WHEEL & TIRE SPECIFICATIONS TABLE (1)

Wheel Size	Tire Size
15 x 6" (Steel)	P195/60HR15
15 x 6.5" (Aluminum)	P195/60HR15
16 x 6.5" (Aluminum)	P205/50ZR16
Temporary Spare (Steel)	T115/70R15

- (1) - Snow chains should be used on the front original equipment tires only.

TIRE INFLATION

Tire specification label is located on the right front door.

TIRE INFLATION SPECIFICATIONS TABLE

Tire Size/Application	psi (kg/cm ²)
195/60R-15	(1)
205/50R-16	(1)
Spare Tire	(1)

- (1) - Check tire pressure label located on the inside of the fuel filler flap.

WHEEL TIGHTENING

Tighten all wheel lug nuts to 80 ft. lbs. (110 N.m) using pattern shown in Fig. 13.

TIRE ROTATION PATTERNS

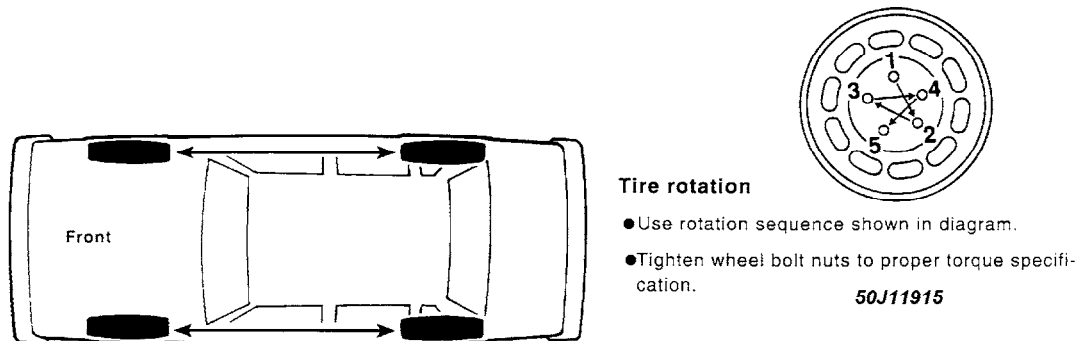

Fig. 13: Tire Rotation Pattern & Lug Nut Torque Pattern
 Courtesy of Volvo Cars of North America.

BATTERY SPECIFICATIONS

CAUTION: When battery is disconnected, vehicles equipped with computers may lose memory data. When battery power is restored, driveability problems may exist on some vehicles. These vehicles may require a relearn procedure. See COMPUTER RELEARN PROCEDURES article in the GENERAL INFORMATION section.

All models use a 520 A/100 Min. battery.

CAUTIONS & WARNINGS

SUPPLEMENTAL RESTRAINT SYSTEM (SRS) AIR BAG SYSTEM

NOTE: See the AIR BAG RESTRAINT SYSTEM article in the ACCESSORIES/SAFETY EQUIPMENT Section.

The SRS has no user-servicable parts. Always have servicing done by an authorized dealer.

When performing maintenance on air bag equipped vehicles always observe proper safety precautions.

WARNING: To avoid injury from accidental air bag deployment, read and carefully follow all warnings and service precautions. See appropriate AIR BAG RESTRAINT SYSTEM article in the ACCESSORIES/SAFETY EQUIPMENT section.

CAUTION: Disconnect negative battery cable before servicing any air bag system, steering column or passenger side dash component. After any repair, turn ignition key to the ON position from passenger's side of vehicle in case of accidental air bag inflation

ANTI-LOCK BRAKE SYSTEM (ABS)

CAUTION: Never mix different diameter tires. On loose or uneven surfaces, the ABS system may require longer stopping distances than conventional brake systems. Exercise caution when removing mud or snow from the wheels so as not to damage the ABS wiring or speed sensors.

BATTERY WARNING

WARNING: When battery is disconnected, vehicles equipped with computers may lose memory data. When battery power is restored, driveability problems may exist on some vehicles. These vehicles may require a relearn procedure. See appropriate COMPUTER RELEARN PROCEDURES article in the GENERAL INFORMATION section below.

REPLACING BLOWN FUSES

Before replacing a blown fuse, remove ignition key, turn off all lights and accessories to avoid damaging the electrical system. Be sure to use fuse with the correct indicated amperage rating. The use of an incorrect amperage rating fuse may result in a dangerous electrical system overload.

BRAKE PAD WEAR INDICATOR

Indicator will cause a squealing or scraping noise, warning that brake pads need replacement.

CATALYTIC CONVERTER

Continued operation of vehicle with a severe malfunction could cause converter to overheat, resulting in possible damage to converter and vehicle.

COOLANT (PROPYLENE-GLYCOL FORMULATIONS)

CAUTION: To avoid possible damage to vehicle use only ethylene-glycol based coolants with a mixture ratio from 44-68% anti-freeze. DO NOT use 100% anti-freeze as it will cause the formation of cooling system deposits. This results in coolant temperatures of over 300° F (149°C) which can melt plastics. 100% anti-freeze has a freeze point of only -8° F (-22°C).

CAUTION: Propylene-Glycol Mixtures has a smaller temperature range than Ethylene-Glycol. The temperature range (freeze-boil) of a 50/50 Anti-Freeze/Water Mix is as follows:

Propylene-Glycol	-26° F (-32°C)	-	257° F (125°C)
Ethylene-Glycol	-35° F (-37°C)	-	263° F (128°C)

CAUTION: Propylene-Glycol/Ethylene-Glycol Mixtures can cause the destabilization of various corrosion inhibitors. Also Propylene-Glycol/Ethylene-Glycol has a different specific gravity than Ethylene-Glycol coolant, which will result in inaccurate freeze point calculations.

ELECTROSTATIC DISCHARGE SENSITIVE (ESD) PARTS

WARNING: Many solid state electrical components can be damaged by static electricity (ESD). Some will display a warning label, but many will not. Discharge personal static electricity by touching a metal ground point on the vehicle prior to servicing any ESD sensitive component.

ENGINE OIL

CAUTION: Never use non-detergent or straight mineral oil.

FUEL SYSTEM SERVICE

WARNING: Relieve fuel system pressure prior to servicing any fuel

system component (fuel injection models).

HALOGEN BULBS

WARNING: Halogen bulbs contain pressurized gas which may explode if overheated. DO NOT touch glass portion of bulb with bare hands. Eye protection should be worn when handling or working around halogen bulbs.

RADIATOR CAP

CAUTION: Always disconnect the fan motor when working near the radiator fan. The fan is temperature controlled and could start at any time even when the ignition key is in the OFF position. DO NOT loosen or remove radiator cap when cooling system is hot.

RADIATOR FAN

WARNING: Keep hands away from radiator fan. Fan is controlled by a thermostatic switch which may come on or run for up to 15 minutes even after engine is turned off.

TURBOCHARGED MODELS

CAUTION: Do not race engine immediately after starting. When stopping engine, allow engine to idle for approximately 60 seconds before shutting it off. Failure to do so may cause turbocharger damage due to lack of oil flowing to the turbocharger bearings.

WHEELS & TIRES

Only wheels tested and approved by the manufacturer should be used on models equipped with Air Dam aerodynamic components.

WARRANTY INFORMATION

CAUTION: Due to the different warranties offered in various regions and the variety of after-market extended warranties available, please refer to the warranty package that came with the vehicle to verify all warranty options.

BASIC WARRANTY

Warranty coverage is 3 years or 50,000 miles, whichever occurs first.

MAJOR ASSEMBLY COVERAGE

Warranty coverage is 3 years or 50,000 miles, whichever occurs first.

CORROSION PROTECTION WARRANTY

Painted body panels are warranted against perforation for a period of 5 years. Structural damage due to rust or corrosion is warranted for 8 years.

SUPPLEMENTAL RESTRAINT SYSTEMS & SEAT BELTS

Factory installed seat belts or restraint systems are warranted for a period of 5 years.

EMISSION SYSTEM WARRANTY

Manufacturer warrants that the vehicle emission control system was designed and installed to conform, at the time of sale, to all applicable U.S. emission standards. The warranty covers repairs resulting from any defect in material or workmanship which could cause the vehicle not to meet emission standards during the warranty period. The warranty period is 5 years or 50,000 miles.

The following components are covered by Emission System or Emission Performance warranties:

- * Ignition Cables
- * Distributor Components
- * Ignition Coil
- * Power Stage
- * Ignition Control Unit
- * Spark Plugs
- * Knock Sensor
- * Engine RPM Sensor
- * Fuel Pressure Regulator
- * Mass Airflow Meter
- * Fuel Injection Control Unit
- * Fuel Injectors
- * Idle Air Valve
- * Coolant Temperature Sensor
- * Throttle Position Sensor
- * Throttle Potentiometer
- * Series Resistor
- * Oxygen Sensor
- * Cold Start Injector
- * Temperature Sensor
- * Manifold Pressure Sensor
- * Camshaft Sensor
- * Evaporative Emission System
- * Turbocharger System
- * PCV System
- * Air Intake System
- * Catalytic Converter
- * Exhaust Manifold
- * Exhaust Pipe (Manifold-To-Catalyst)
- * EGR System
- * Miscellaneous Items Used In Above System

FUSES & CIRCUIT BREAKERS

The fuse panel is located in the engine compartment. A label on the inside of the cover lists the fuse amperage and circuits protected.

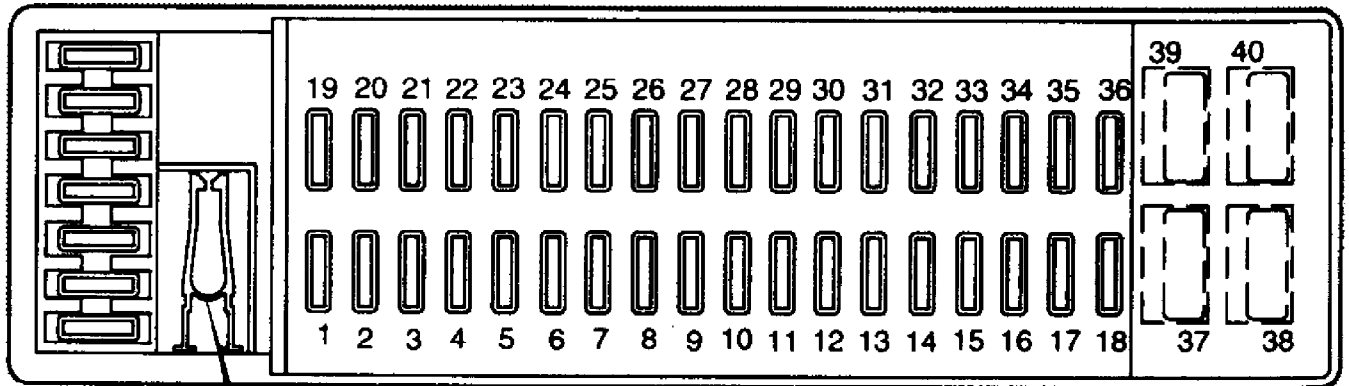

93C45544

Fig. 14: Fuse Panel Identification
 Courtesy of Volvo Cars of North America.

Fuse & Circuit Breaker Identification

- 1 - 15 Amp
 Fuel Injection, Distributor Ignition, Automatic Gearbox
- 2 - 15 Amp
 Fuel Pump, Alarm System
- 3 - 10 Amp
 Courtesy Lights, Oil Level Sensor
- 4 - Not Used (1993-95)
 10 Amp (1996)
 Electronic Start Inhibitor (Immobilizer)
- 5 - 30 Amp
 ECC Blower (Speed 4)
- 6 - 25 Amp
 Central Locking System, Alarm
- 7 - 15 Amp
 Audio System (Amplifier)
- 8 - 25 Amp (1993-95)
 Power Antenna, Trailer Connector
 40 Amp (1996)
 Electronic Start Inhibitor (Immobilizer)
- 9 - 30 Amp
 ABS, Traction Control System
- 10 - Not Used (1993-95)
 15 Amp (1996)
 Heated Rear Seat (If Equipped)
- 11 - 30 Amp
 Heated Rear Window & Side Mirrors
- 12 - 10 Amp
 Brake Lights
- 13 - 15 Amp
 Hazard Flashers, Headlight Flashers, Alarm
- 14 - 30 Amp
 ABS, Traction Control System
- 15 - 10 Amp (1993-95)
 Audio System, Courtesy Lights, Door Open Light, Trunk Light,
 Glove Box Light, Remote Control Central Locking System,
 Oil Level Sensor, Seat Belt Reminder
 10 Amp (1996)
 Audio System, Courtesy Lights, Door Open Light, Trunk Light,
 Glove Box Light, Remote Control Central Locking System,
 Oil Level Sensor, Seat Belt Reminder, Data Link Connector
- 16 - 30 Amp (1993-95)

- Accessories
- 30 Amp (1996)
Power Antenna, Trailer Connector, Accessories
- 17 - 10 Amp
Key Reminder
- 18 - 25 Amp (1993-95)
Heated Front Seats, Power Mirrors
- 15 Amp (1996)
Front Fog Lamps
- 19 - 15 Amp
Left High Beam Headlight
- 20 - 15 Amp
Right High Beam Headlight, High Beam Indicator
- 21 - 15 Amp
Left Low Beam Headlight
- 22 - 15 Amp
Right Low Beam Headlight
- 23 - 10 Amp
Left Parking Light, License Light
- 24 - 10 Amp
Right Parking Light, Bulb Failure Warning Sensor
- 25 - 10 Amp
Rear Fog Lamps, Fog Lamp Indicator
- 26 - Not Used (1993-95)
25 Amp (1996)
Heated Front Seats, Power Mirrors
- 27 - 15 Amp
Back-Up Lights, Turn Signals
- 28 - 10 Amp
Cruise Control, Heated Rear Window, Seat Belt Reminder Light,
Shiftlock, Bulb Failure Warning Sensor, Heated Rear Seat
- 29 - 15 Amp
ABS, Traction Control System
- 30 - 10 Amp
Cigarette Lighter
- 31 - 25 Amp
ECC, ECC Blower (Speeds 1-3)
- 32 - 10 Amp
Audio System, Remote Controlled Central Locking System
- 33 - 15 Amp (1993-95)
Power Seats, OBD Test Socket, Tailgate Washer/Wipe (Wagon)
- 15 Amp (1996)
Power Seats, Tailgate Washer/Wipe (Wagon)
- 34 - 25 Amp
Windshield Wiper/Washer, Horn, Headlight Washer/Wiper
- 35 - 10 Amp
Instrument Lights, Sun Roof, Traction Control System
- 36 - Not Used
- 37 - Circuit Breaker
Power Windows, Power Sun Roof
- 38 - Not Used
- 39 - Circuit Breaker
Drivers Power Seat
- 40 - Circuit Breaker
Passengers Power Seat

RELAY PANEL LOCATION

The relay panel is located at the left corner of the instrument panel.

RELAY PANEL IDENTIFICATION

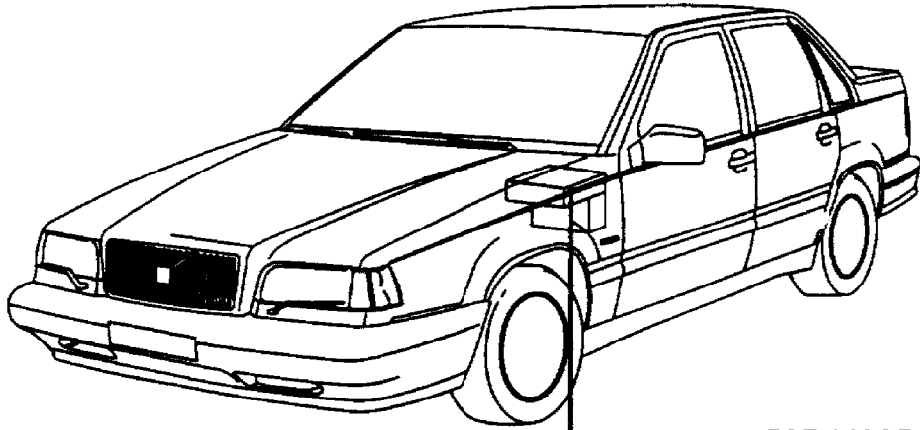

50B11925

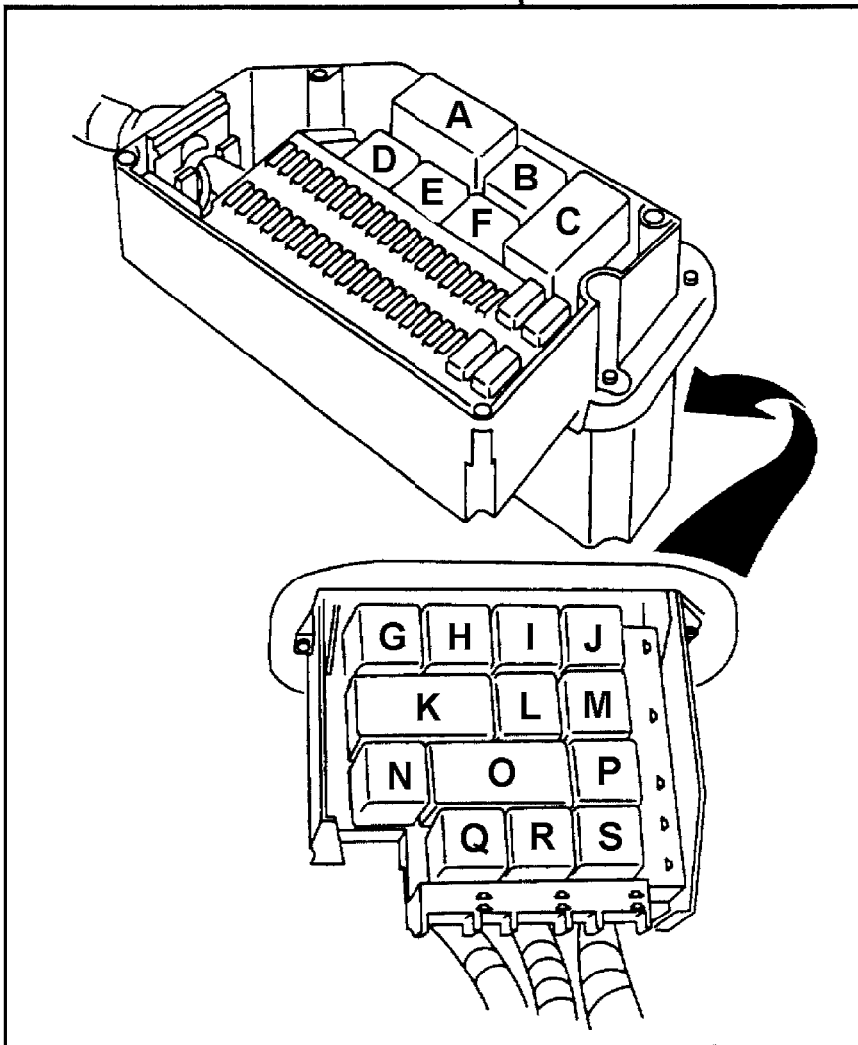

Fig. 15: Relay Panel Identification
Courtesy of Volvo Cars of North America.

Relay Identification

A - Control Module, Cruise Control
B - Fuel Pump Relay
C - Main Headlight Relay with Bulb Malfunction Indicator
D - Overload Relay (+X Supply)
E - Overload Relay (+15 Supply)
F - Overload Relay (+X Supply)
G - Fog Lamp Relay
H - Deadlock Setting Relay
I - Intermittent Windshield Wiper Relay
J - Intermittent Wiper Relay (Rear Tailgate - Wagon)
K - Central Lock and Delayed Inside Lighting Relay
L - Speed Warning Relay
M - Heated Rear Window and Door Mirror Relay
N - Not Used
O - Anti-Theft Alarm Relay
P - Seat Belt Reminder/Key Warning Relay
Q - Front Fog Lamp (Bridge)
R - Heated Rear Seat Relay
S - Not Used