

COOLING SYSTEM SPECIFICATIONS

1995 Volvo 850

ENGINE COOLING
Cooling System Specifications

1994-96: 850, 960

BELT ADJUSTMENT SPECIFICATIONS

BELT ADJUSTMENT

Application	(1) Deflection - In. (mm)
850 & 960	(2)

- (1) - Deflection is measured with moderate thumb pressure applied midway on longest belt run.
- (2) - Belt is self-adjusting. See Fig. 1.

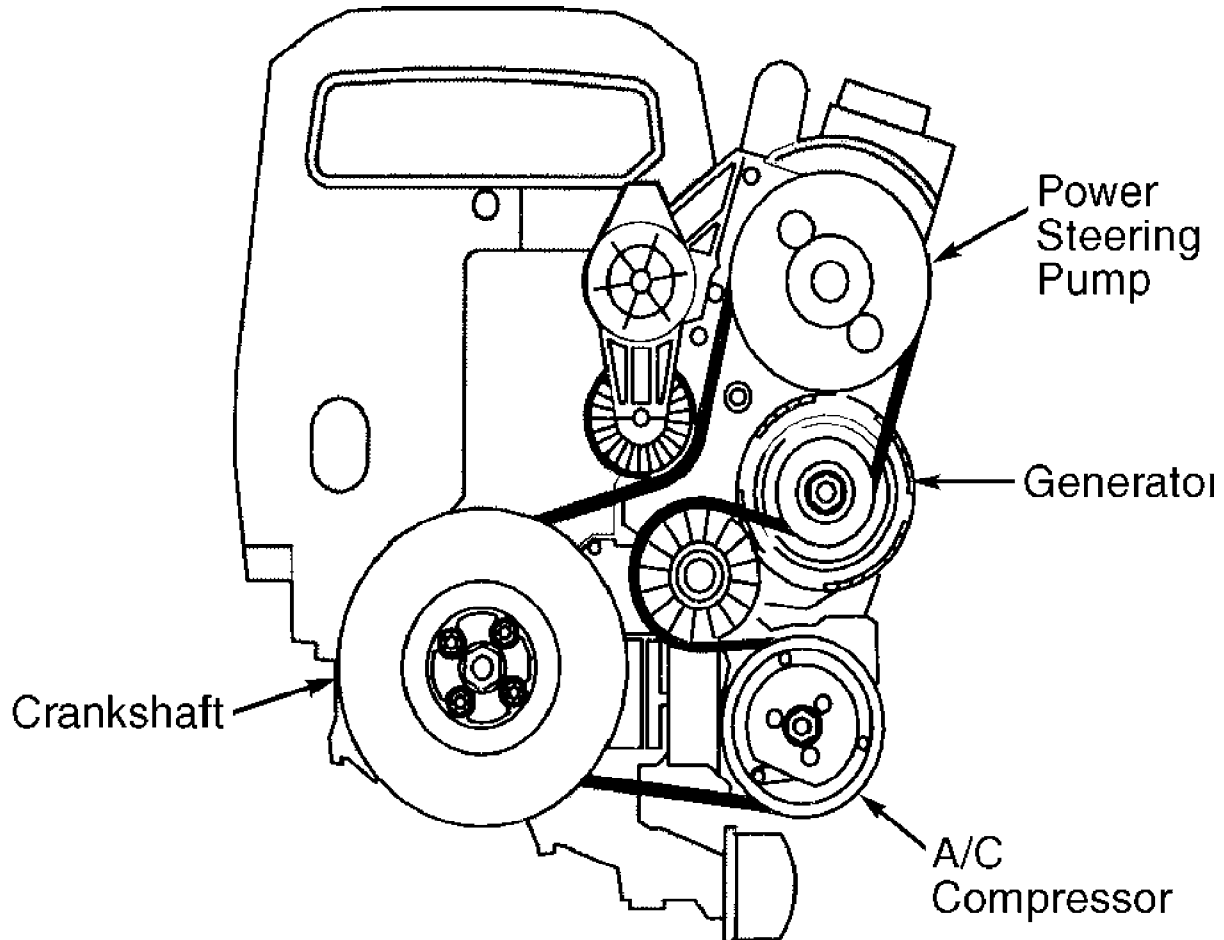

96E18741

Fig. 1: Identifying Belt Routing (850 & 960)
Courtesy of Volvo Cars of North America.

COOLING SYSTEM SPECIFICATIONS

Model	Specification
Coolant Replacement Interval	(1)
Coolant Capacity	
850	
Non-Turbo	7.6 Qts. (7.2L)
Turbo	7.4 Qts. (7.0L)
960	10.5 Qts. (10L)
Thermostat Opens	
Starts (2)	186°F (90°C)
Fully Open	216°F (102°C)

- (1) - Manufacturer does not require routine coolant replacement.
- (2) - Turbo thermostat starts opening at 180°F (87°C).

WIRING DIAGRAMS

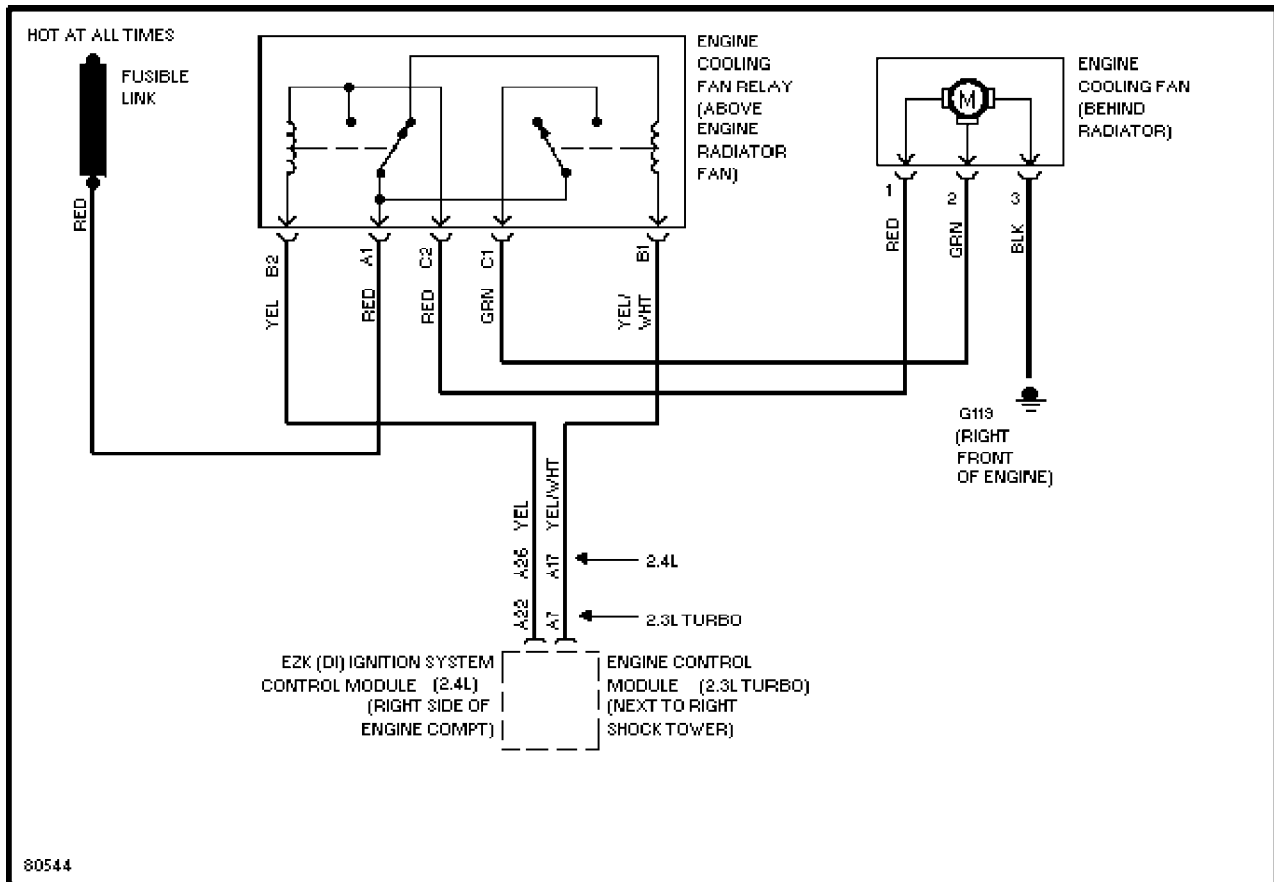
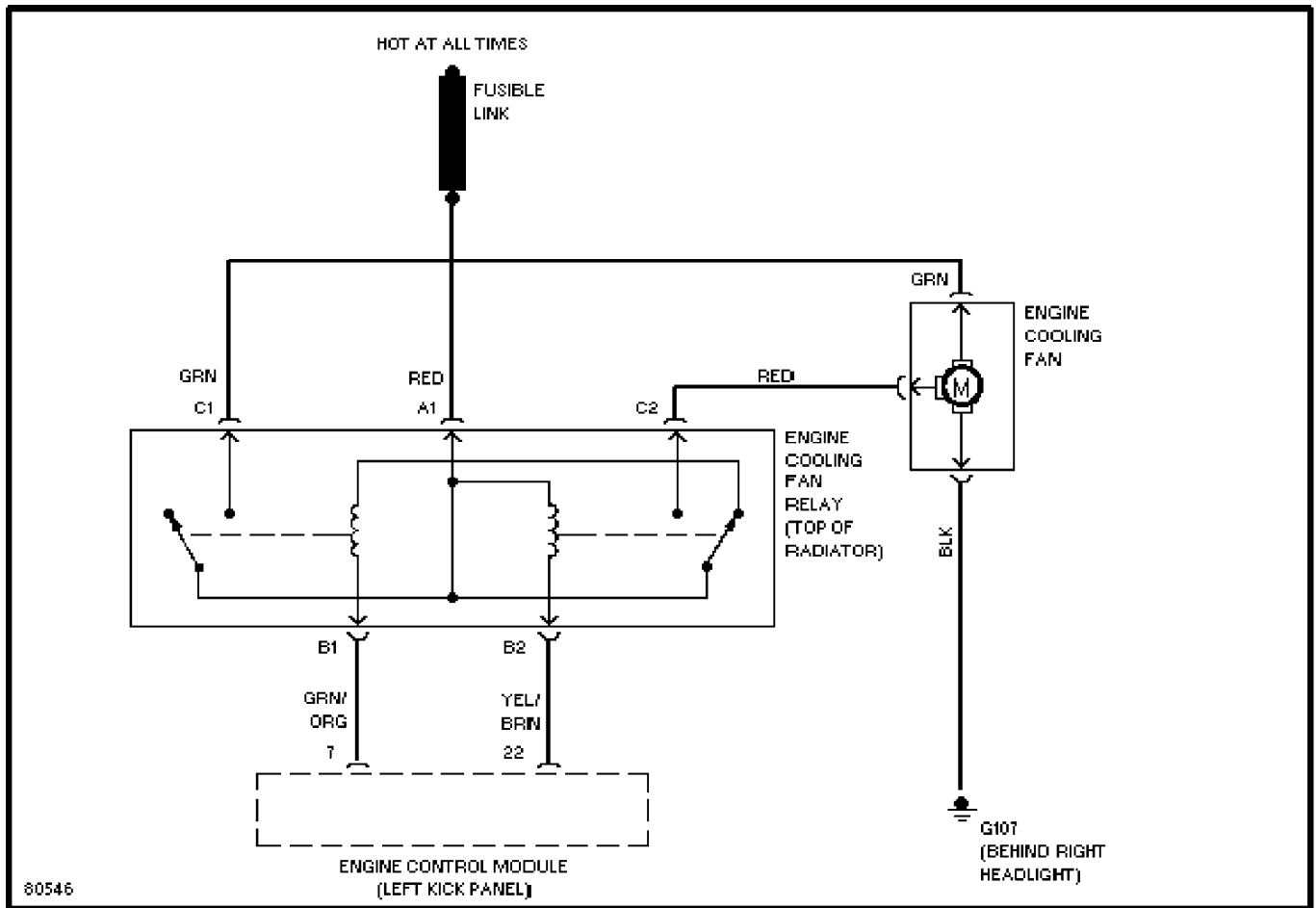

Fig. 2: Electric Cooling Fan System Schematic (850)
 Courtesy of Volvo Cars of North America



80546

Fig. 3: Electric Cooling Fan System Schematic (1960)